



# HYDRA<sup>®</sup>

**ELECTRIC VEHICLE CHARGERS**



## **DION**

DC Wall-Mounted/Pedestal EV Charger

### **ELECTRIC VEHICLE CHARGER INSTALLATION AND INSTRUCTION MANUAL**

# CONTENTS



**HYDRA**<sup>®</sup>  
ELECTRIC VEHICLE CHARGERS

<b>SAFETY</b> .....	<b>3</b>
<b>INTRODUCTION</b> .....	<b>6</b>
Appearance .....	6
Technical Specifications.....	8
Product Features.....	9
<b>INSTALLATION</b> .....	<b>10</b>
Procedure.....	10
Wall Mount Installation.....	11
Pedestal Mount Installation .....	12
Wiring.....	13
<b>SCREEN INSTRUCTIONS</b> .....	<b>14</b>
Idle & Insert Connector.....	14
RFID Swipe & Start Charging .....	15
Charging and Charging information.....	16
Settings & Login .....	17
Network Settings .....	18
OCPP Settings.....	19
<b>AFTER-SALES MAINTENANCE</b> .....	<b>20</b>
After Sales Service .....	20
Maintenance.....	21
<b>PROCEDURES</b> .....	<b>22</b>
<b>SUPPORT</b> .....	<b>22</b>

# HYDRA









## SAFETY ANNOUNCEMENTS

Before operating the EV charger, read the instructions and precautions carefully to reduce the risk of accidents. The “caution, warning, hazard” notices in the product and product manual do not represent all safety concerns to be observed and are only intended to supplement the various operational safety precautions.

In carrying out the company’s product and equipment operations, you must comply with relevant industry safety norms and strictly abide by these instructions to provide the appropriate equipment precautions and special safety instructions

## IDENTIFICATION DESCRIPTION

	Indicates that care must be taken with the operation or condition of hazardous voltage
	Important security information must be followed very carefully
	Indicates risk of burns from high-temperature areas or areas with high component temperatures
	Ground protected connection point
	AC electricity
	DC electricity
	Indicates that the said action must be performed using clothing and/or personal protective equipment provided by the employer



## ELECTRICAL SAFETY

### HIGH VOLTAGE



Some components of the power system operate with high voltage. Direct or indirect contact with these components through non-insulated protective material poses a fatal hazard.

The installation of AC power supply equipment must comply with safety regulations, and personnel carrying out the installation of AC equipment must be qualified in high voltage AC-power operation.

It is strictly prohibited to wear watches, bracelets, rings or other conductive objects on your wrist or hand.

Turn off the power immediately if you find water or moisture in the unit. When operating in humid conditions, water should be strictly prevented from entering the equipment.

A "Do not operate" sign must be hung on switches and buttons that are not to be used during installation.



Construction of high-voltage lines can cause fire or electric shock accidents. The racking and wiring of AC cables through the area must comply with the local regulations and specifications. Only personnel qualified for high-voltage and AC operations can carry out various high-voltage operations.

### TOOLS



Special tools must be used for all high AC voltage operations.

### THUNDERSTORMS



High AC voltage operations during thunderstorms are strictly prohibited.

Strong electromagnetic fields are produced in the atmosphere during thunderstorms. To avoid lightning damage to equipment and personnel, do not carry out any operations during thunderstorms.

### ELECTROSTATICS



Static electricity generated by the human body can damage electrostatic-sensitive components on boards such as large-scale integrated circuits (ICs). To prevent static damage to sensitive components, personnel must wear an anti-static bracelet when in contact with equipment (hand-held boards, circuit boards, IC chips, etc.). The anti-static bracelet must be well-grounded on the other end.

# SAFETY



**HYDRA**<sup>®</sup>  
ELECTRIC VEHICLE CHARGERS

## SHORT CIRCUITS



It is strictly prohibited to short-circuit the power supply system to the positive and negative poles or to short the non-ground pole to ground during operation. Short circuits can cause equipment to burn and pose a personal safety hazard.

In addition, the polarity of the cables and interface terminals must be strictly checked when carrying out live work.

Power distribution operation space is limited. Before any operation, close attention must be paid to the choice of operating space.

An insulation tool must be used during operation.

When working with electricity, care must be taken to keep your hands, wrists and arms steady, to prevent accidents from a tool slipping, or from too much movement of a tool or your body.

## SHARP CORNERS



When moving equipment by hand, wear protective gloves to prevent cuts.

## POWER CABLE



Make sure that the cable label is correct before connecting the cable.

## SIGNAL LINE



The signal cable should be tied separately from the power cable and at least 15mm away.

# INTRODUCTION



**HYDRA**<sup>®</sup>  
ELECTRIC VEHICLE CHARGERS

## APPEARANCE

Use	Commercial or Workplace Parking
Material	Metal
Installation type	Wall-Mounted/Pedestal
Cable layout	Bottom (Side Mounted)
Weight	Charger: 64-70kg Charging Cable: 6kG
Cable length	4.5m
Charging socket	CCS2

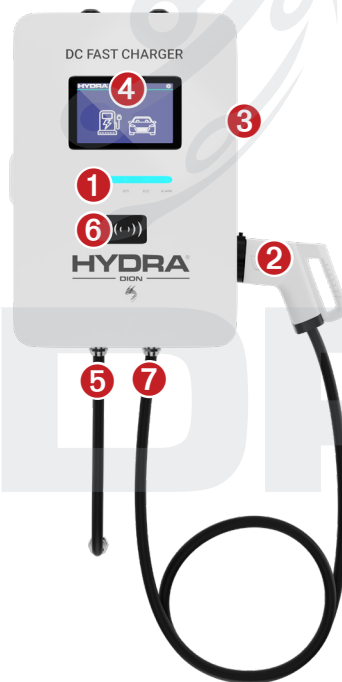

- 1 Status indicator light
- 2 Charging Lead
- 3 Emergency Stop and Reset Button
- 4 LCD Screen
- 5 Power Cable inlet
- 6 RFID Scanner
- 7 Cable Plug inlet

# INTRODUCTION



**HYDRA**<sup>®</sup>  
ELECTRIC VEHICLE CHARGERS

## TECHNICAL SPECIFICATIONS

Model		HD-20-DC-BLK	HD-30-DC-BLK	HD-40-DC-BLK
AC Input	Input Rating	AC380V(±15%) 3ph	AC380V(±15%) 3ph	AC380V(±15%) 3ph
	AC Input Connection	3P+N+PE	3P+N+PE	3P+N+PE
	Rate Input Current	3Ø33A	3Ø50A	3Ø66A
	Frequency	50/60Hz	50/60Hz	50/60Hz
	Power Factor	≥ 0.99	≥ 0.99	≥ 0.99
	Efficiency	≥ 95%	≥ 95%	≥ 95%
DC Output	Output Voltage Range	200V-1000V	200V-1000V	200V-1000V
	Max Output Current	66A(system)	80A(system)	133A(system)
	Max output Power	DC20kW	DC30kW	DC40kW
	Voltage Accuracy	≤ ±0.5%	≤ ±0.5%	≤ ±0.5%
	Current Accuracy	≤ ±1%	≤ ±1%	≤ ±1%
COMPONENT SPECIFICATIONS	Dimensions	20 & 30kW = 500(H)mm x 370(W)mm x 290(D)mm 40kW = 790(H)mm x 580 (W)mm x 29 (D)mm		
	Weight	64-70kg		
	Cable length	4.5m		
	Shell material	Metal		
	Screen	10.1" LCD touch screen		
POWER CHARACTERISTICS	Input voltage	Three Phase AC 380 ±15% (3P+N+PE)		
	Input frequency	50hz/60hz ±1Hz		
	Rated power	20kW & 30kW models (One output) 40kW model (Two outputs, single 40kW or double 20kW)		
	Measurement accuracy	≤±0.5%		
	Output voltage	DC 150~1000V		
	Output current	100A		
	Input Current	50A per phase		
	Efficiency	≥94%		
Factor	≥0.99			

# INTRODUCTION



**HYDRA**<sup>®</sup>  
ELECTRIC VEHICLE CHARGERS

## TECHNICAL SPECIFICATIONS

DESIGN FEATURES	UI	Emergency stop button, LED indicator
	Charging Method	RFID Plug and charge, APP (timed start and stop) 17
	Charging Cable	CCS2
COMMUNICATION	Web interface	WiFi, Wired Ethernet, 3G/4G
	OCPP	OCPP 1.6J
WORKING ENVIRONMENT	Use	Indoor/Outdoor
	Operating temperature	-30°C ~ +55°C
	Operating humidity	5% to 95%
	Elevation	<2000m
	Protection level	IP55
	Enclosure Protection	IK10
	Cooling method	Ambient air cooling
	Ground detection	30mA
	Sound level	≤50db (normal input/output power at ambient 25°C)
	RoHS	Meets the R5 requirements of the RoHS directive

# HYDRA



# INTRODUCTION



**HYDRA**<sup>®</sup>  
ELECTRIC VEHICLE CHARGERS

## PRODUCT FEATURES

The HYDRA DION DC Charger has a modern design and user-friendly interface, designed for Commercial and workplace use.

### SAFETY FEATURES

- ⚡ Hardware protection features:
  - ⚡ Emergency stop protection
  - ⚡ Overcurrent protection
  - ⚡ Earth leakage protection
- ⚡ Comprehensive software protection features, providing multiple protections
- ⚡ IP55, EMC class B/C

### SMART

- ⚡ The terminal charger is connected to the Open Charge Point Protocol platform online
- ⚡ Remote diagnostics, remote upgrades
- ⚡ Compatible with GB/T, Type1-SAEJ1772, Type 2 and IEC61851-1/2017
- ⚡ OCPP Smart charging
- ⚡ Support for OCPP1.6-J (later direct upgrade to 2.0)

### CONVENIENT

- ⚡ Wireless or wired communication, flexible networking
- ⚡ Open communication protocol for sweep charge, swipe charging and API services
- ⚡ Several settings to end the charge
  - ⚡ Time limit
  - ⚡ Amount of electricity

### OPTIONAL FEATURES

- ⚡ Plug&Charge (optional)

# HYDRA

# INSTALLATION



**HYDRA**<sup>®</sup>  
ELECTRIC VEHICLE CHARGERS

## PROCEDURE

### SAFETY INSTRUCTIONS

The operating voltage and current inside the charging system are high, and the following regulations should be observed at all times to ensure personal safety:

1. Charging systems must only be installed by personnel who have been trained in, and have sufficient knowledge of, the charging system. Always follow safety precautions and local safety regulations during installation.
2. To operate inside the charging system, make sure that the charging system is not live. The power input to the charging system must be disconnected.
3. Distribution cable wiring should be reasonable and protective to avoid accidental contact when operating power supplies.

### VISUAL INSPECTION

Upon product delivery, check that the package is not damaged and that the label is complete and correct. If there is an issue, immediately inform the carrier and take photos as evidence. At the same time, immediately contact the manufacturer to discuss the issue.

Only after the goods arrive at the installation site can they be opened and the boxes opened for inspection. Start by opening the box with the packing slip, taking out the packing list and checking it against each item. Next, check the serial number of the box, the equipment packaging, the number and type of accessories and the integrity of all items.

Following the packing list, check that accessories and accompanying documents are complete (refer to the shipping list) and store the accessories and documents properly.

Carry out a visual inspection to ensure that the product is free of abnormal marks showing collisions, and of scratches, cracks, dents, rust, breakage, or peeling of paint.

Sign receipt documents, make a record of the situation, keep documents and scan them for archives, or give them to relevant parties.

### ACCESSORY LIST

The packing list comes with the shipping documents.

# INSTALLATION



**HYDRA**<sup>®</sup>  
ELECTRIC VEHICLE CHARGERS

## WALL MOUNTED INSTALLATION

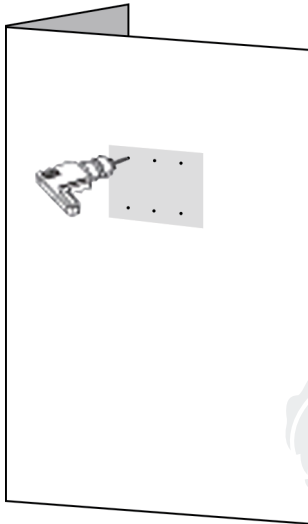

1. Select the appropriate installation position and drill the screw holes positions according to the mounting plate mark.

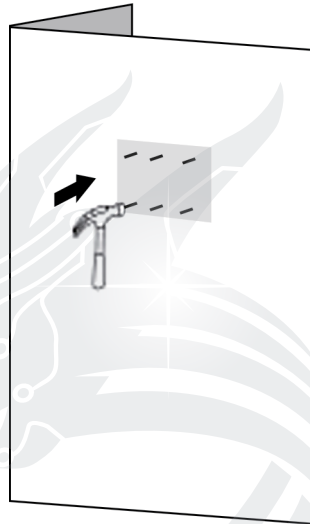

2. Knock the expansion pipe into the hole

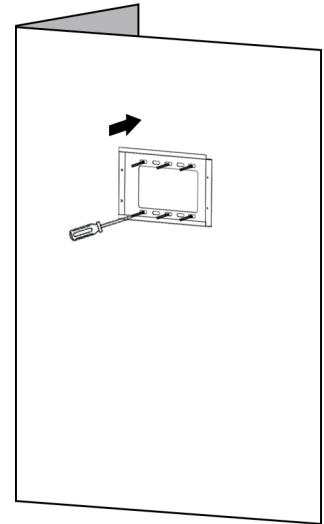

3. Use M10/M12 bolts to horizontally fix the mounting plate to the wall.

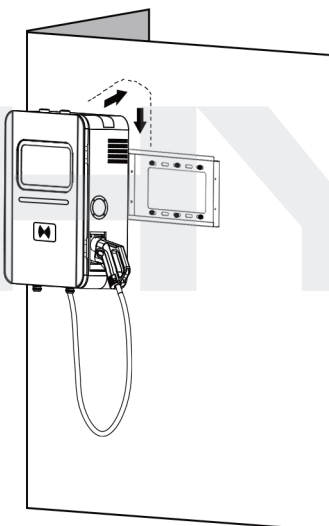

4. Hang the charger on the mounting plate.

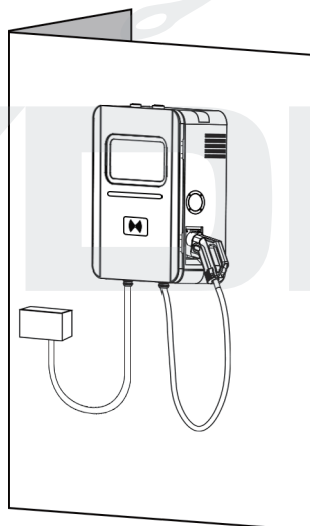

5. After installation, connect the incoming line (minimum 3 x 16mm<sup>2</sup> for the live cables and 2 x 10mm<sup>2</sup> for earth and neutral) to the power supply.



## PEDESTAL INSTALLATION

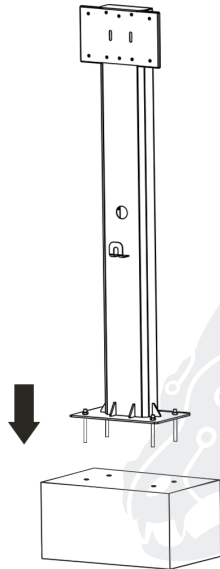

1. Install the column in place

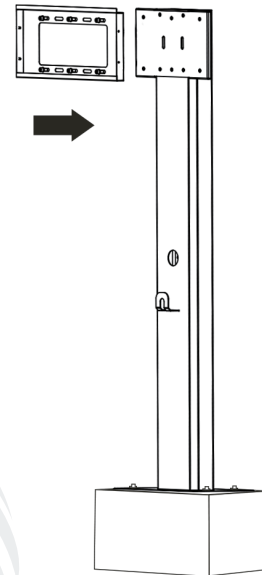

2. Use M10/M12 bolts to fix the mounting plate on the column (holes are reserved on the column).

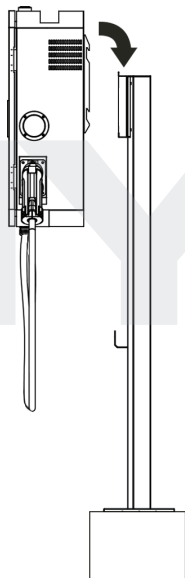

3. Hang the charger on the mounting plate.

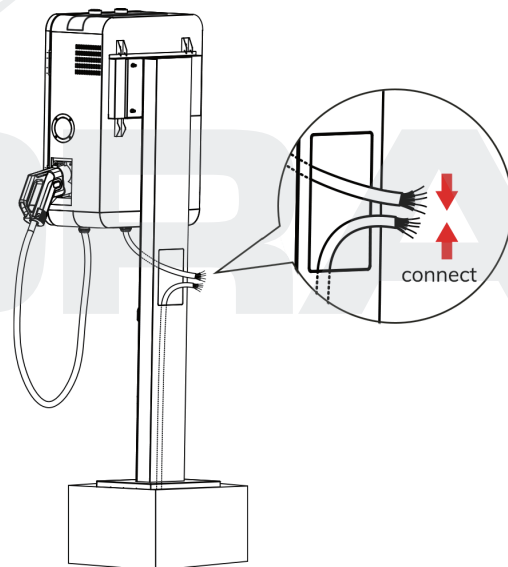

4. After installation, connect the incoming line (minimum 3 x 16mm<sup>2</sup> for the live cables and 2 x 10mm<sup>2</sup> for earth and neutral) to the power supply.

# INSTALLATION



**HYDRA**<sup>®</sup>  
ELECTRIC VEHICLE CHARGERS

## WIRING



Colour	Brown	Black	Grey	Blue	Yellow & Green
Phase order	L1	L2	L3	N	PE

# SCREEN INSTRUCTIONS



**HYDRA**<sup>®</sup>  
ELECTRIC VEHICLE CHARGERS

## 1. IDLE

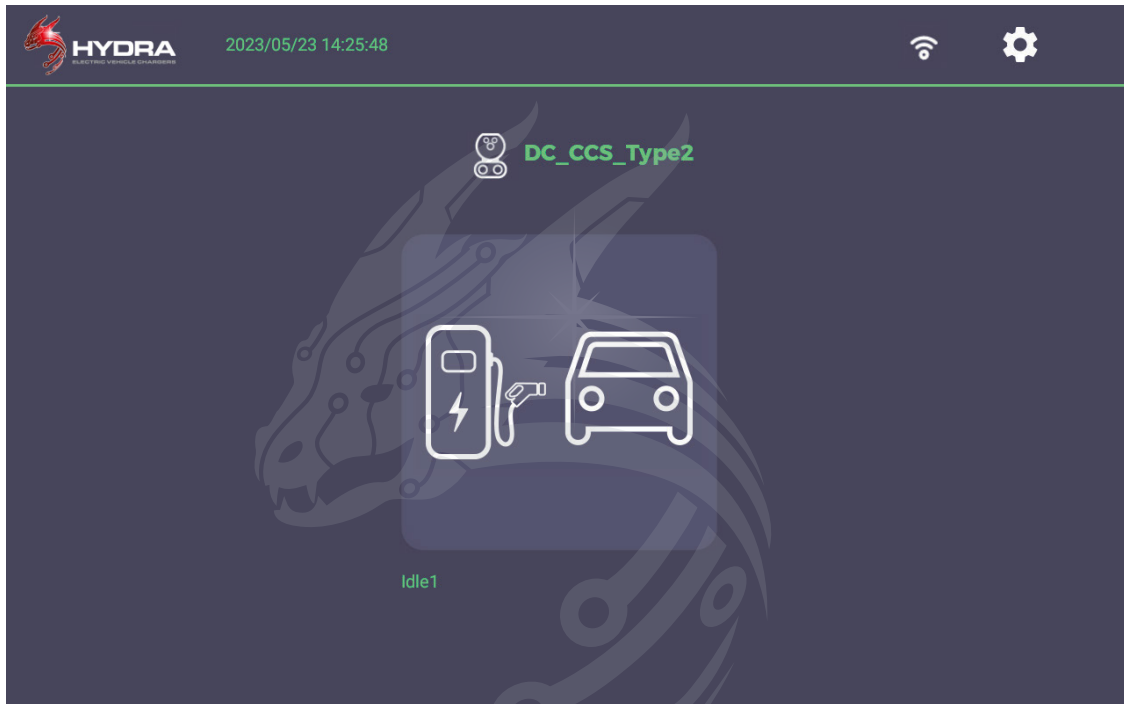

## 2. INSERT CONNECTER & CLICK RFID

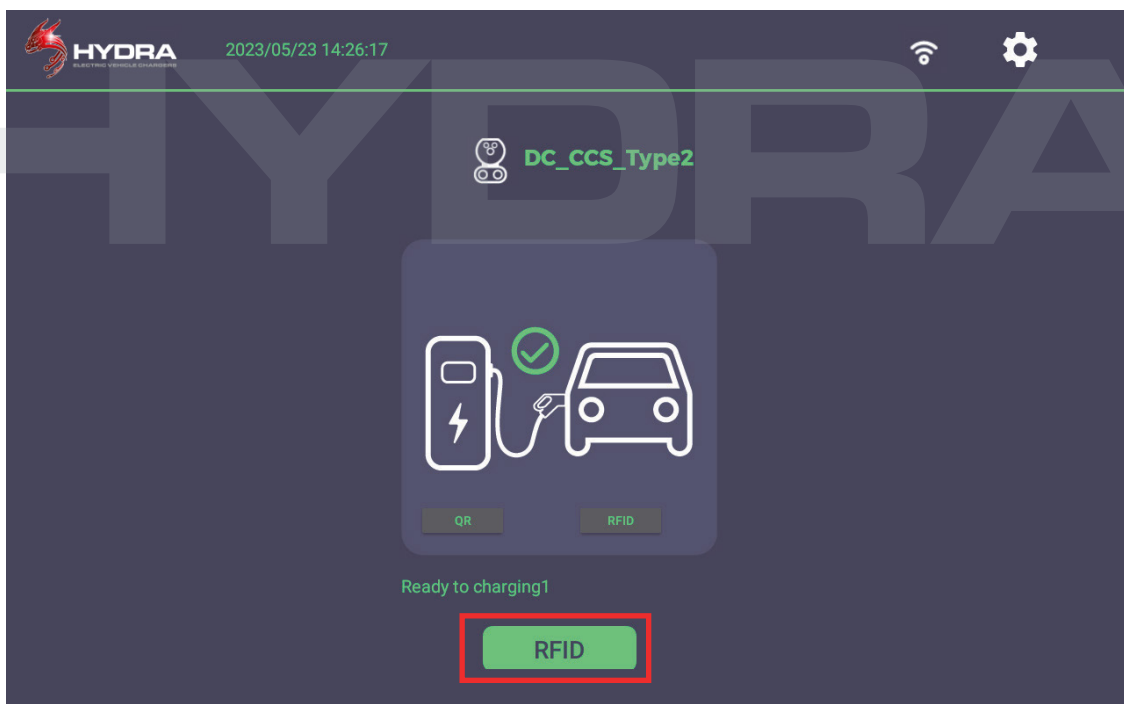

# SCREEN INSTRUCTIONS



**HYDRA**<sup>®</sup>  
ELECTRIC VEHICLE CHARGERS

## 3. SWIPE THE RFID CARD

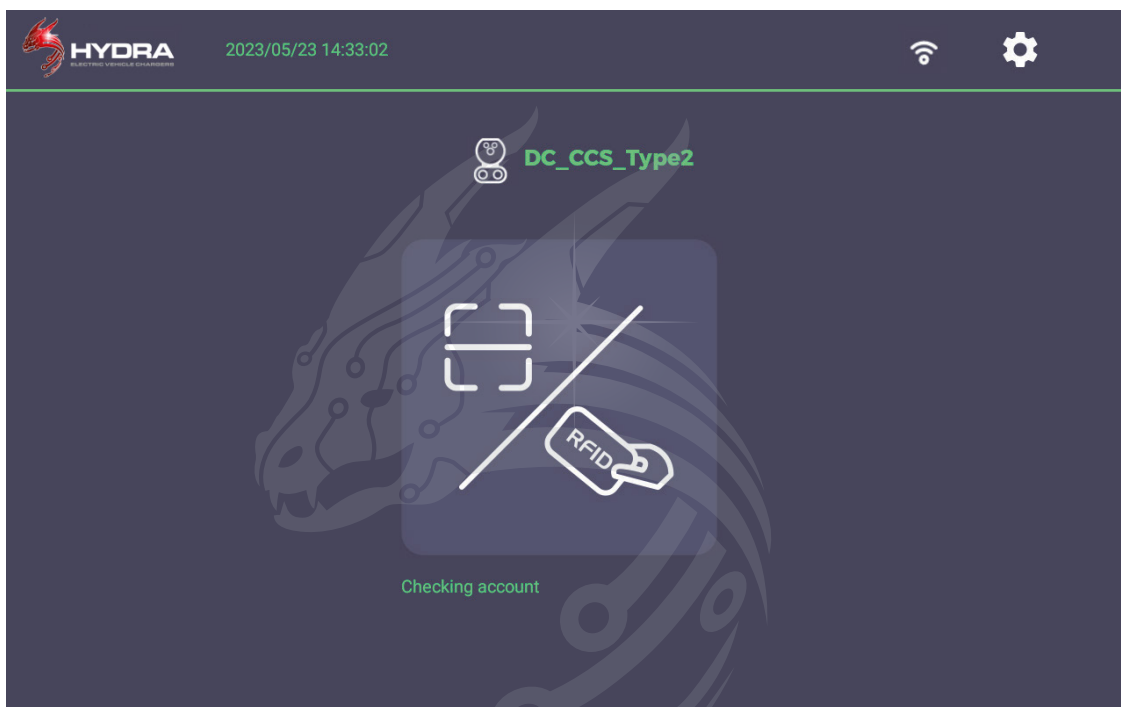

## 4. START CHARGING

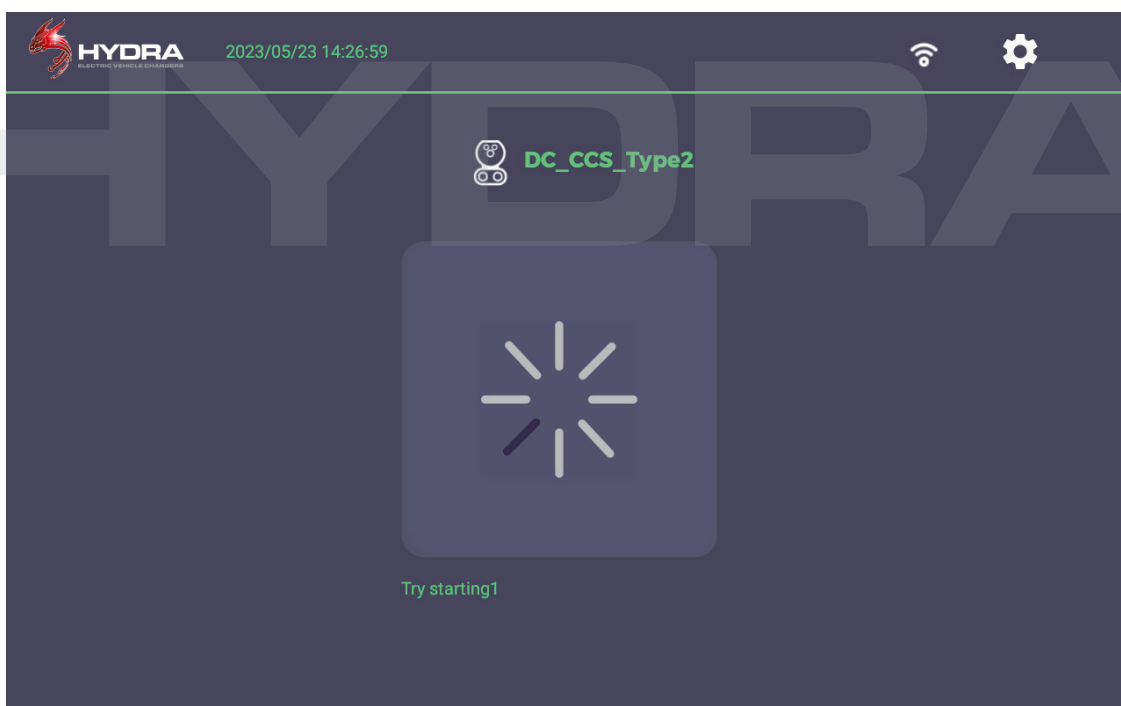

# SCREEN INSTRUCTIONS



**HYDRA**<sup>®</sup>  
ELECTRIC VEHICLE CHARGERS

## 5. CHARGING

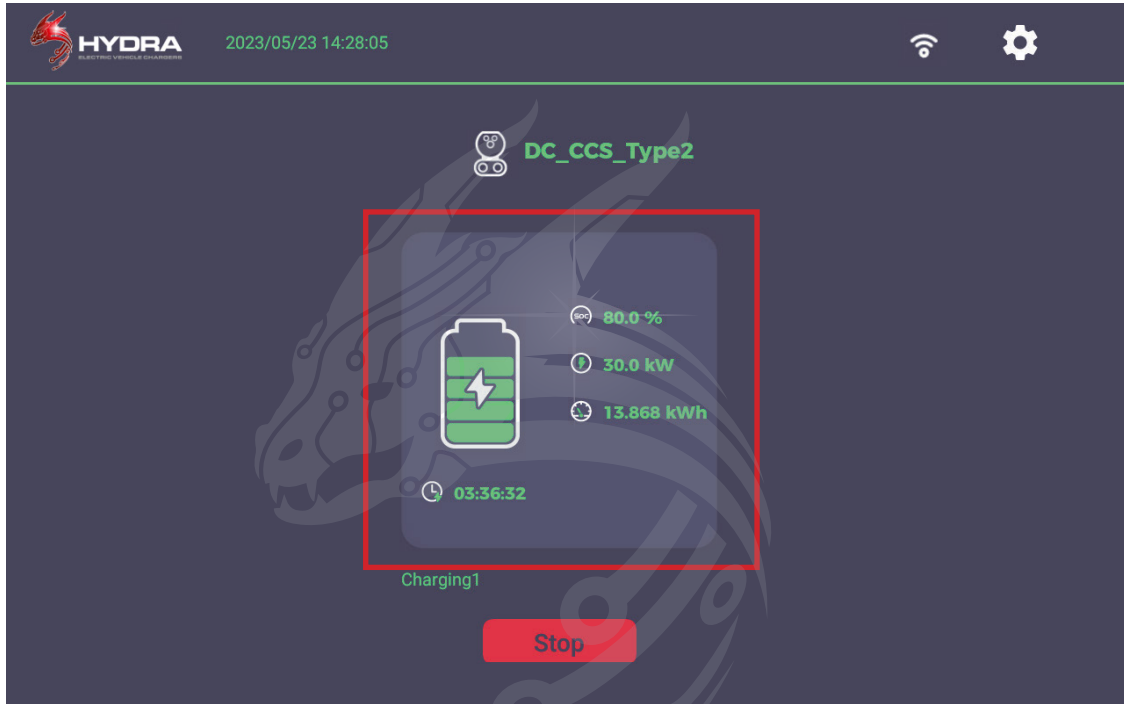

## 6. CLICK THE BATTERY TO VIEW CHARGING INFORMATION

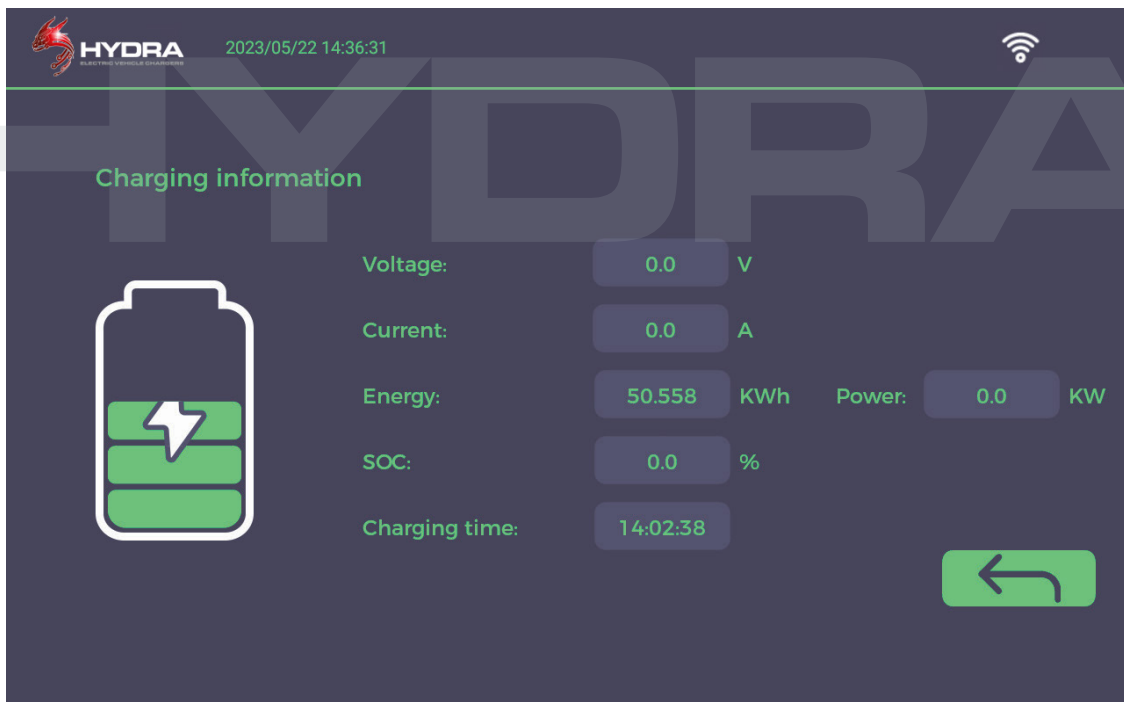



# SCREEN INSTRUCTIONS



**HYDRA**<sup>®</sup>  
ELECTRIC VEHICLE CHARGERS

## 1. CLICK THE COG

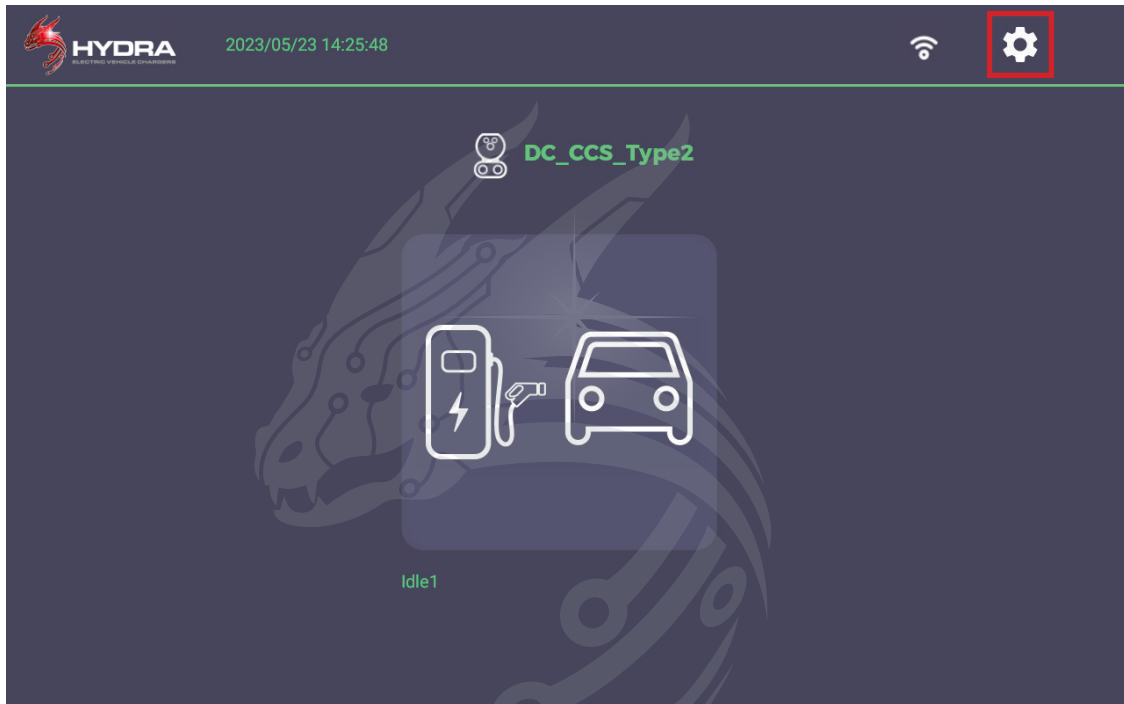

## 2. ENTER 123456 FOR PASSWORD



# SCREEN INSTRUCTIONS



**HYDRA**<sup>®</sup>  
ELECTRIC VEHICLE CHARGERS

## 1. CLICK NETWORK SETTINGS

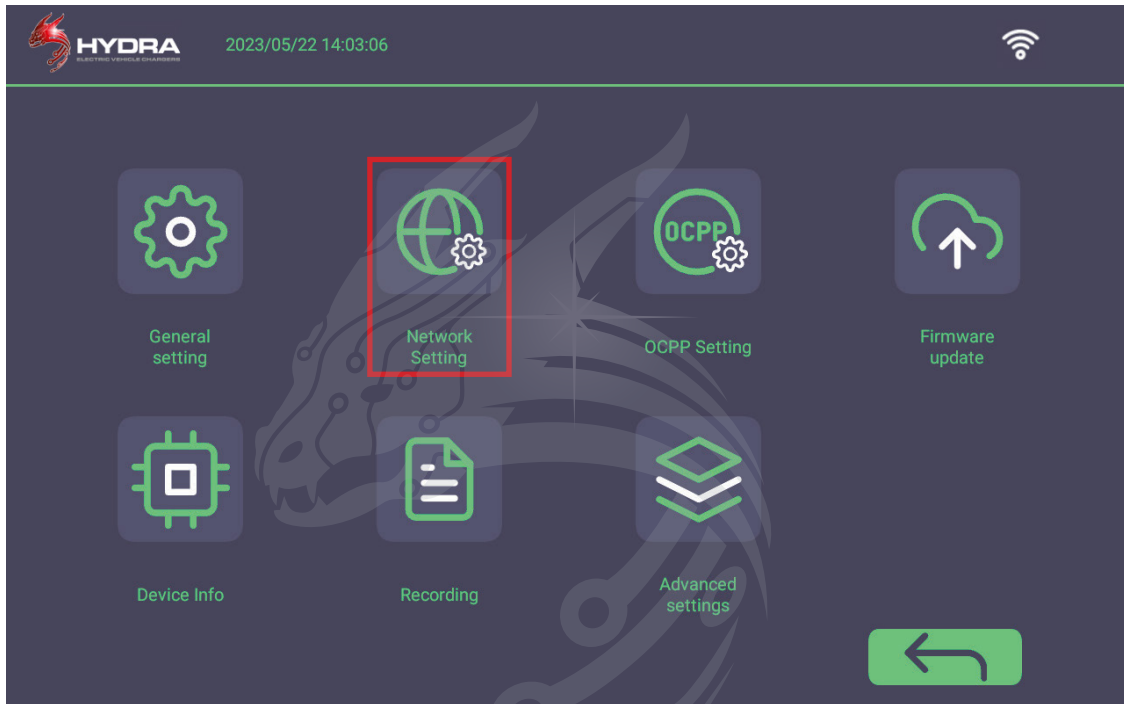

## 2. NETWORK SETTINGS & NETWORK SELECTION

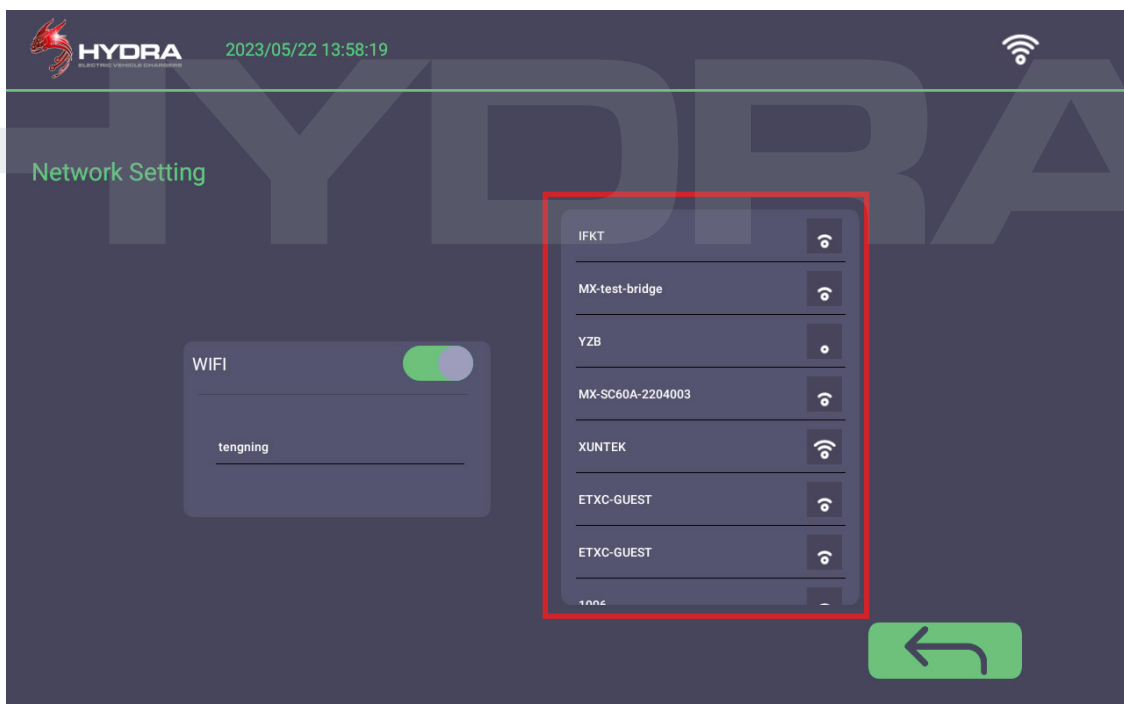

# SCREEN INSTRUCTIONS



**HYDRA**<sup>®</sup>  
ELECTRIC VEHICLE CHARGERS

## 1. CLICK OCPP SETTINGS



## 2. ENTER DETAILS

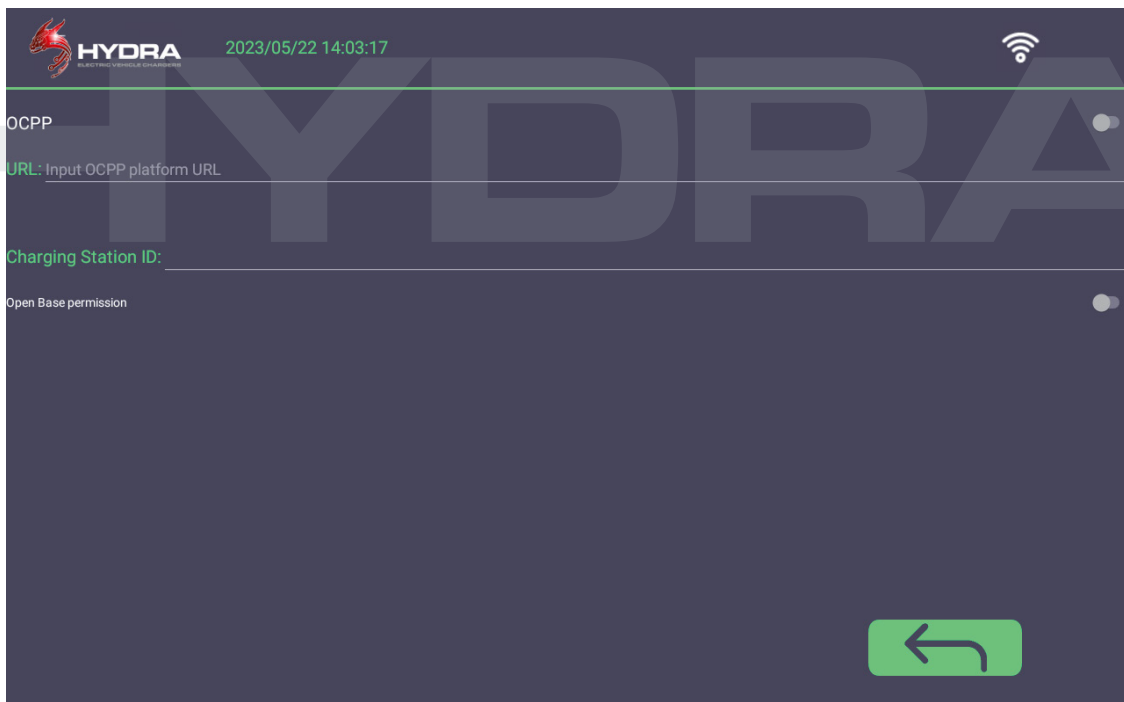

# AFTER-SALES MAINTENANCE



**HYDRA**<sup>®</sup>  
ELECTRIC VEHICLE CHARGERS

## AFTER-SALES SERVICE

- ⚡ Parts are covered by a 12 months warranty.
- ⚡ During this period any defective part will be replaced.
- ⚡ One-to-one technical engineer support is available.

## DISCLAIMER

Product equipment must be used under certain conditions. Should the following circumstances lead to an accident or damage, we will not be held responsible.

- ⚡ All human factors, damage and use in an abnormal working environment
- ⚡ Failures and damage caused by improperly using the device or not following instructions.
- ⚡ Damage caused by transport after delivery.
- ⚡ Normal wear, breach or immersion.
- ⚡ Use of parts not authorised by the manufacturer (such as aftermarket or counterfeit parts).
- ⚡ Dismantling, repairing or modifying the products without the prior consent of the company.
- ⚡ Damage caused by flood, fire, lightning strike, typhoons, earthquakes or abnormal voltage.
- ⚡ Accidents, faults or damages outside the warranty period.

## MAINTENANCE

### DAILY MAINTENANCE

Regular servicing maintains the charger's safety and condition.

### REGULAR MAINTENANCE

#### MONTHLY

- ⚡ Check the charger is still perfectly upright.
- ⚡ Clean any dirt on the outer surface.
- ⚡ Check for damage to the painted surface.
- ⚡ Test the charging outlets and cables.
- ⚡ Check the LED display status.

#### QUARTERLY

- ⚡ Check the ground screw and ground resistance (no greater than 1Ω).
- ⚡ Check the charger's alarm light is green and the module is working.

*continued...*

# AFTER-SALES MAINTENANCE



**HYDRA**<sup>®</sup>  
ELECTRIC VEHICLE CHARGERS

## MAINTENANCE

### SEMI-ANNUALLY

- ⚡ Check ground bolt torque and tighten if required.

### ANNUALLY

- ⚡ Check all internal components.

### ON-SITE MAINTENANCE

This device is an internet of Things-type charger with pre-charge self-test, daily regular self-test, online monitoring of electrical parts and other intelligent functions.

- ⚡ If working, simply perform routine maintenance, no overhaul maintenance is required.
- ⚡ If not working properly, promptly contact the customer service centre or local supplier.

### REMOTE MAINTENANCE

The charger has the function of connecting to the device cloud platform to monitor the status of the charger in real time. When connected, the platform can provide perfect remote diagnosis, remote service and remote upgrade services. It can also locate problems and provide solutions to help the operation centre carry out remote services. It can remotely upgrade software, solve end-user problems and carry out unattended operations.

- ⚡ The system self-tests daily. If there is an issue, it will escalate it automatically.
- ⚡ If there is an abnormal operation, please contact the customer service centre or local supplier promptly.
- ⚡ Service engineers can query logs, update configuration and procedures, carry out remote management, diagnosis, configuration, upgrades and other remote maintenance actions.

# HYDRA

# PROCEDURES



**HYDRA**<sup>®</sup>  
ELECTRIC VEHICLE CHARGERS

## DURING INSTALLATION, REPAIR AND REPLACEMENT OF SPARE PARTS

- ⚡ Live work is strictly prohibited.
- ⚡ Unauthorised dismantling is strictly prohibited.
- ⚡ Follow safety procedures when operating the equipment.
- ⚡ Access to the power supply line should be followed in the PE ground -> zero-line -> phase line order.
- ⚡ All operations must comply strictly with relevant safety standards.

## AFTER INSTALLATION, REPAIR AND REPLACEMENT OF SPARE PARTS

- ⚡ Refer to the installation and maintenance requirements for validation and testing.
- ⚡ Bring your own tools to restore the internal switch.
- ⚡ Lock the safety door for the device to operate safely.

### END OF LIFE DISPOSAL

When a product reaches the end of its useful life, or is damaged beyond use for any reason and needs to be scrapped, contact your local council.

# HYDRA

# SUPPORT



**HYDRA**<sup>®</sup>  
ELECTRIC VEHICLE CHARGERS

## SUPPORT CONTACT DETAILS

If you require any assistance feel free to contact us on the details below:

**Telephone: 01268 205 121**

**Email: [support@hydraev.co.uk](mailto:support@hydraev.co.uk)**

**website: [www.hydraev.co.uk](http://www.hydraev.co.uk)**



# HYDRA



# HYDRA

**HYDRA EVC Ltd**

Telephone: 01268 205 121

Email: [sales@hydraev.co.uk](mailto:sales@hydraev.co.uk)

Unit 11, Totman Close, Rayleigh, Essex SS6 7UZ