



# HYDRA

ELECTRIC VEHICLE CHARGERS



# HYDRA

## ECHO

AC Wall-Mounted EV charger

**ELECTRIC VEHICLE CHARGER  
INSTALLATION AND INSTRUCTION MANUAL**

# CONTENTS



**HYDRA**<sup>®</sup>  
ELECTRIC VEHICLE CHARGERS

<b>SAFETY</b> .....	<b>3</b>
Safety Identification .....	3
<b>INTRODUCTION</b> .....	<b>6</b>
Appearance .....	6
Technical Specifications.....	7
Technical Specifications (Continued).....	8
Product Features.....	9
<b>INSTALLATION</b> .....	<b>10</b>
Procedure.....	10
Network connectivity requirements .....	11
Tool preparation .....	12
Socket and Tethered.....	13
Internal Structure.....	14
Product Parameter .....	15
List of Products and Accessories .....	16
Site Space Requirements .....	17
Installation Instructions .....	18
Electrical Requirements.....	19
Installation Step 1 .....	20
Installation Step 2 .....	21
Installation Step 3 .....	22
Installation Step 4 .....	23
Installation Step 5 .....	24
<b>AFTERSALES</b> .....	<b>25</b>
Aftersales Service .....	25
Disclaimer .....	25
Maintenance.....	25
Procedures.....	25
During Installation.....	26
After Installation.....	26
<b>PROCEDURES</b> .....	<b>27</b>
<b>APPENDIX</b> .....	<b>28</b>
Fault Diagnostics.....	28











## SAFETY ANNOUNCEMENTS

Before operating the EV charger, read the instructions and precautions carefully to reduce the risk of accidents. The “caution, warning, hazard” notices in the product and product manual do not represent all safety concerns to be observed and are only intended to supplement the various operational safety precautions.

In carrying out the company’s product and equipment operations, you must comply with relevant industry safety norms and strictly abide by these instructions to provide the appropriate equipment precautions and special safety instructions

## IDENTIFICATION DESCRIPTION

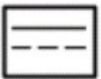
	Indicates that care must be taken with the operation or condition of hazardous voltage
	Important security information must be followed very carefully
	Indicates risk of burns from high-temperature areas or areas with high component temperatures
	Ground protected connection point
	DC electricity
	AC electricity
	Indicates that the said action must be performed using clothing and/or personal protective equipment provided by the employer
	Type A Residual Current Devices (RCD)
	Type B Residual Current Devices (RCD)



## ELECTRICAL SAFETY

### HIGH VOLTAGE



Some components of the power system operate with high voltage. Direct or indirect contact with these components through non-insulated protective material poses a fatal hazard.

The installation of AC power supply equipment must comply with safety regulations, and personnel carrying out the installation of AC equipment must be qualified in high voltage AC-power operation.

It is strictly prohibited to wear watches, bracelets, rings or other conductive objects on your wrist or hand.

Turn off the power immediately if you find water or moisture in the electric cabinet. When operating in humid conditions, water should be strictly prevented from entering the equipment.

A "Do not operate" sign must be hung on switches and buttons that are not to be used during installation.



Construction of high-voltage lines can cause fire or electric shock accidents. The racking and wiring of AC cables through the area must comply with the local regulations and specifications. Only personnel qualified for high-voltage and AC operations can carry out various high-voltage operations.

### TOOLS



Special tools must be used for all high AC voltage operations.

### THUNDERSTORMS



High AC voltage operations during thunderstorms are strictly prohibited.

Strong electromagnetic fields are produced in the atmosphere during thunderstorms. To avoid lightning damage to equipment and personnel, do not carry out any operations during thunderstorms.

### ELECTROSTATICS



Static electricity generated by the human body can damage electrostatic-sensitive components on boards such as large-scale integrated circuits (ICs). To prevent static damage to sensitive components, personnel must wear an anti-static bracelet when in contact with equipment (hand-held boards, circuit boards, IC chips, etc.). The anti-static bracelet must be well-grounded on the other end.

# SAFETY



**HYDRA**<sup>®</sup>  
ELECTRIC VEHICLE CHARGERS

## SHORT CIRCUITS



It is strictly prohibited to short-circuit the power supply system to the positive and negative poles or to short the non-ground pole to ground during operation. Short circuits can cause equipment to burn and pose a personal safety hazard.

In addition, the polarity of the cables and interface terminals must be strictly checked when carrying out live work.

Power distribution operation space is limited. Before any operation, close attention must be paid to the choice of operating space.

An insulation tool must be used during operation.

When working with electricity, care must be taken to keep your hands, wrists and arms steady, to prevent accidents from a tool slipping, or from too much movement of a tool or your body.

## SHARP CORNERS



When moving equipment by hand, wear protective gloves to prevent cuts.

## POWER CABLE



Make sure that the cable label is correct before connecting the cable.

## SIGNAL LINE



The signal cable should be tied separately from the power cable and at least 15mm away.

# INTRODUCTION



**HYDRA**<sup>®</sup>  
ELECTRIC VEHICLE CHARGERS

## APPEARANCE

Use	Car Parks / Public Charging Station
Material	Metal housing
Installation type	Wall Mounted
Cable layout	Bottom
Weight	5-10kg
Cable length	4m
Charging socket	Type2

- 1 Touch Screen
- 2 Door Lock
- 3 RFID Card reader
- 4 LED status lights
- 5 Power input
- 6 RJ45 input
- 7 Charger Output (tethered)

Not shown:  
Charger cable socket  
(untethered model)



# INTRODUCTION



**HYDRA**<sup>®</sup>  
ELECTRIC VEHICLE CHARGERS

## TECHNICAL SPECIFICATIONS

COMPONENT SPECIFICATIONS	Dimensions	500(H)mm x 370(W)mm x 290(D)mm
	Weight	5kg (no cable) -10kg (with cable)
	Cable length	≥4.2m/SOCKET
	Shell material	Aluminium Alloy
	Screen	5" LCD touch screen
POWER CHARACTERISTICS	Input voltage	TN-S 240V AC (single phase) 400V AC (three phase) ±10%
	Input frequency	50hz/60hz
	Rated power	7kW (single phase) 22kW (three phase)
	Measurement accuracy	≤±0.5%
	Output voltage	Same as input voltage
	Output current	7kW/22kW-32A
	Efficiency	≥94%
	Factor	≥0.99
DESIGN FEATURES	UI	RFID Card Reader, LCD touch screen, Emergency Stop Button
	Standard	GB/T, TYPE2 and IEC61851-1/2017
COMMUNICATION	Web interface	Wired Ethernet, 3G/4G
	OCPP	OCPP 1.6J

# INTRODUCTION



**HYDRA**<sup>®</sup>  
ELECTRIC VEHICLE CHARGERS

## TECHNICAL SPECIFICATIONS (CONTINUED)

WORKING ENVIRONMENT	Use	Indoor/Outdoor
	Operating temperature	-30°C ~ +55°C
	Operating humidity	5% to 95%
	Elevation	<2000m
	Protection level	IP55
	Cooling method	Ambient air cooling
	Ground detection	30mA
	Sound level	≤50db (normal input/output power at ambient 25°C)
	RoHS	Meets the R5 requirements of the RoHS directive

# HYDRA



# INTRODUCTION



**HYDRA**<sup>®</sup>  
ELECTRIC VEHICLE CHARGERS

## PRODUCT FEATURES

The HYDRA ECHO AC Charger has a modern design and user-friendly interface, designed for domestic and workplace use.

### SAFETY FEATURES

- ⚡ Hardware protection features:
  - ⚡ Overcurrent protection
  - ⚡ Overvoltage protection
  - ⚡ Over-temperature protection
  - ⚡ Emergency stop protection
  - ⚡ Lightning protection
  - ⚡ Type B RCD
- ⚡ Comprehensive software protection features, providing multiple protections
- ⚡ Meets IEC61851-22 requirements
- ⚡ All components have CE certificates
- ⚡ The SECC controller has gone through the TÜV test

### SMART

- ⚡ The terminal charger is connected to the Open Charge Point Protocol platform online
- ⚡ Remote diagnostics, remote upgrades
- ⚡ Compatible with GB/T Type 2 and IEC61851-1/2017
- ⚡ Internal high-precision MID AC meter
- ⚡ Supports simultaneous charging of multiple connectors
- ⚡ The OCPP platform sets the maximum output power according to the time period
- ⚡ Support for credit card Point Of Sale payment (optional)
- ⚡ Support for OCPP1.6-J (later direct upgrade to 2.0)

### CONVENIENT

- ⚡ Wireless or wired communication, flexible networking
- ⚡ Open communication protocol for sweep charge, swipe charging and API services
- ⚡ Several settings to end the charge
  - ⚡ Time limit
  - ⚡ Amount of electricity
  - ⚡ Auto filled

### OPTIONAL FEATURES

- ⚡ Plug&Charge (optional)

# INSTALLATION



**HYDRA**<sup>®</sup>  
ELECTRIC VEHICLE CHARGERS

## PROCEDURE

### SAFETY INSTRUCTIONS

The operating voltage and current inside the charging system are high, and the following regulations should be observed at all times to ensure personal safety:

1. Charging systems must only be installed by personnel who have been trained in, and have sufficient knowledge of, the charging system. Always follow safety precautions and local safety regulations during installation.
2. To operate inside the charging system, make sure that the charging system is not live. The power input to the charging system must be disconnected.
3. Distribution cable wiring should be reasonable and protective to avoid accidental contact when operating power supplies.

### VISUAL INSPECTION

Upon product delivery, check that the package is not damaged and that the label is complete and correct. If there is an issue, immediately inform the carrier and take photos as evidence. At the same time, immediately contact the manufacturer to discuss the issue.

Only after the goods arrive at the installation site can they be opened and the boxes opened for inspection. Start by opening the box with the packing slip, taking out the packing list and checking it against each item. Next, check the serial number of the box, the equipment packaging, the number and type of accessories and the integrity of all items.

Following the packing list, check that accessories and accompanying documents are complete (refer to the shipping list) and store the accessories and documents properly.

Carry out a visual inspection to ensure that the product is free of abnormal marks showing collisions, and of scratches, cracks, dents, rust, breakage, or peeling of paint.

Sign receipt documents, make a record of the situation, keep documents and scan them for archives, or give them to relevant parties.

### ACCESSORY LIST

The packing list comes with the shipping documents.

# INSTALLATION



**HYDRA**<sup>®</sup>  
ELECTRIC VEHICLE CHARGERS

## NETWORK CONNECTIVITY REQUIREMENTS

The recommended way to connect to the network is to access 4G wireless communication. A SIM card meeting local networking requirements is required. Make sure the local signal strength is strong and stable; otherwise a signal amplifier must be installed.

If there is no local 4G communication signal, a standard wired internet connection is available. Wired connections must meet the following requirements:

- ⚡ RJ45 Ethernet
- ⚡ Network cable type: 5e class or greater, 8P plus PE, shielding wire.
- ⚡ It is recommended that the line length is less than 75m. Greater than 75m length requires a customised engineering solution.
  
- ⚡ Minimum bandwidth required:
  - ⚡ Upstream: 128 kbps
  - ⚡ Downstream: 4 Mbps
  
- ⚡ Demand connection reliability: 99.9%.
  
- ⚡ For special configurations, please contact us.

# HYDRA

# INSTALLATION



**HYDRA**<sup>®</sup>  
ELECTRIC VEHICLE CHARGERS

## TOOL PREPARATION

### STANDARD TOOLS

NAME	DESCRIPTION	QTY
Multimeter	Checking the electrical connections and electrical parameters	1
Electric impact drill	Drilling	1
Impact drill bit (Ø 14mm)	Drilling	2
Tape measure (5m)	Measurement	1
Level ruler	Measurement	1
Crosshead screwdriver	Unpacking	1
Pliers	Unpacking	1
Wire Stripper	Removing the insulation sheath / jacket	1
Terminal pressure line pliers	Pressing the terminals	1
Bevel cutting pliers	Cutting the cable	1
Light hammer	Unpacking, tapping, adjustment	1
Carrying equipment	Moving and hoisting charger	1
PVC tape and sheath	Insulation tape and insulation cladding connection	1
Personal protection tools	Ensuring the health and safety of operators	1

# HYDRA

# INSTALLATION



**HYDRA**<sup>®</sup>  
ELECTRIC VEHICLE CHARGERS

## SOCKET

- 1.LCD Screen
- 2.Rfid
- 3.LED Light
- 4.Type2 Socket
- 5.LAN port
- 6. E-STOP



## TETHERED

- 1.LCD Screen
- 2.Rfid
- 3.LED Light
- 4.Type2 Socket
- 5.LAN port
- 6. E-STOP





## INTERNAL STRUCTURE

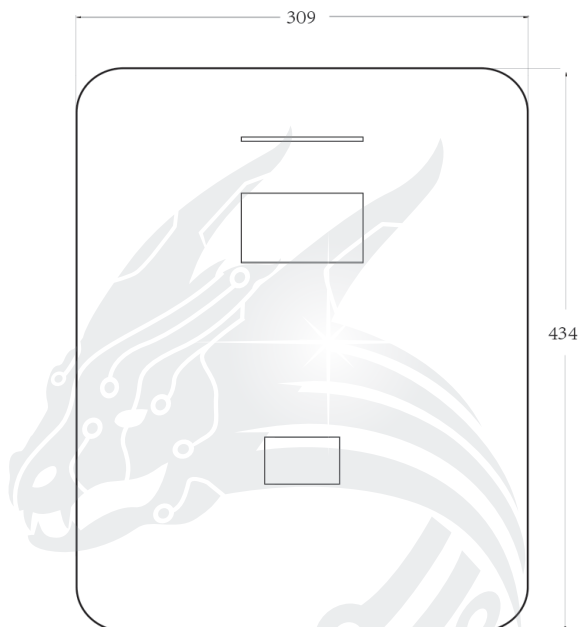

- 1. LED Light Bar
- 2. 4.3 inch screen
- 3. RFID Card Module



## INTERNAL STRUCTURE

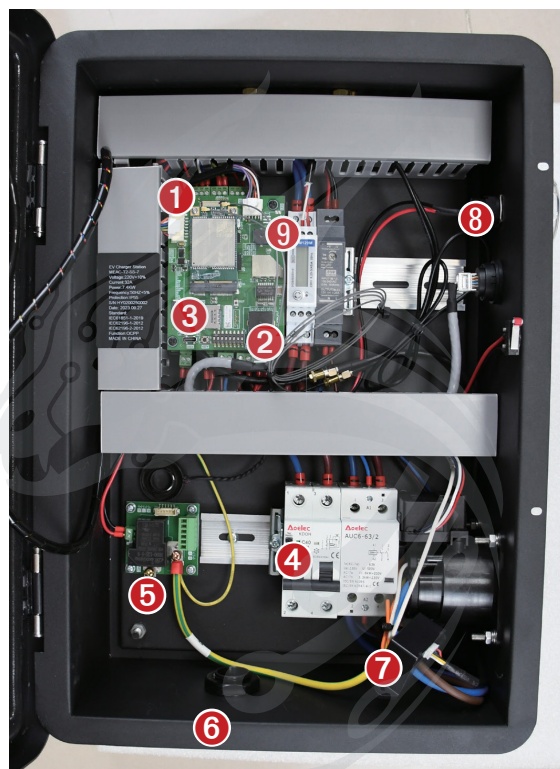

- 1 Motherboard
- 2 LAN Port
- 3 SIM
- 4 RCD Switch
- 5 Protective Earth
- 6 Input Power Wires
- 7 A+6 leakage insurance
- 8 LAN Port Extension Cable
- 9 MID Certified Electric Meter

# INSTALLATION



**HYDRA**<sup>®</sup>  
ELECTRIC VEHICLE CHARGERS

## PRODUCT PARAMETERS

Product Series	Commercial-SINGLE Tethered	Commercial-SINGLE SOCKET
Charging interface	IEC 61851 GB/T 20234 GB/T 18487-2015, GB/T 20234-2015	IEC 61851
Input Voltage Range	220VA ± 20% (1-phase) / 380VA ± 20%(3-phase)	
Output Voltage Range	220VA ± 20% (1-phase) / 380VA ± 20%(3-phase)	
Rated output current	32A	
Rated power	7kW/ 22KW	
Working Frequency	45/65 Hz	
Networking method	4G/LAN	
Bluetooth	N/A	
Control mode	OCPP1.6 J (QR code / RFID)	
IP grade	≥ IP55	
Working Temperature	-40 °C ~ + 60 °C	
Working Humidity	5%-95% Non-condensing	
Special Protection	UV resistance	
Working altitude	≤ 2000m	
Operating instructions	On-screen display / Buzzer	
Status indication	On-screen display /LED breathing light	
Application Scenario	Outdoor indoor parking and charging	
Weight	~ 11kg	~10kg
Dimension	500(H)mm x 370(W)mm x 290(D)mm	500(H)mm x 370(W)mm x 190(D)mm



# INSTALLATION



**HYDRA**<sup>®</sup>  
ELECTRIC VEHICLE CHARGERS

## LIST OF PRODUCTS AND ACCESSORIES

S/N	Name	Specification / Material	Quantity	Remarks
1	EV Charging Station	EV Charger Body	1	
2	Installation Manual		1	
3	Expansion Screw	M10X80	4	For installation of EV Charging station and ground
4	Anti-theft Screws	M4X10 with lock core	4	For wall brackets 1 and 2 to be mounted to the body of the EV Charging station
5	Wall Mounting Brackets 1,2		2	
6	Charging Card	RFID Card	3	

# HYDRA

# INSTALLATION



**HYDRA**<sup>®</sup>  
ELECTRIC VEHICLE CHARGERS

## INSTALLATION INSTRUCTIONS

### TRANSFER LOADING AND UNLOADING

- ⚡ Do not drop or hit the device.

### INSTALLATION

- ⚡ Secure the base to the wall.

NB: To avoid the back plate distorting when being screwed onto the wall, it is recommended that you fix each screw loosely one at a time and then tighten slowly once all screws are in place.

- ⚡ Carefully and slowly lower the charger into place.
- ⚡ Make sure that the cable has been passed into the cabinet along the seal sleeve.
- ⚡ Ensure that the cabinet holes and bolts are aligned.
- ⚡ Lock the nuts to 95.5 Nm.
- ⚡ Keep the device upright – do not tilt more than  $\pm 15^\circ$
- ⚡ Mount the charging pile on the hanger and lock the charging pile

# HYDRA



## ELECTRICAL REQUIREMENTS

Cable type: Three-phase, five-core (TN-C-S/TN-S) confirming the need for shielding as required by local laws or norms. Single Phase, three core, as above.

- ⚡ Cable diameter requirements are determined by the contractor or electrical engineer, based on power, distance and industry standards, or the following recommendations:
  - ⚡ ZR-YJV-multi-core-sheath power cable.
  - ⚡ The voltage level is 450/750V or higher.
  - ⚡ A temperature of at least 90°C should be achieved.
- ⚡ PE Safety ground wire requires the same size model as the N wire, or uses the following recommended requirements:
  - ⚡ When the phase line is greater than 35 mm<sup>2</sup>, the ground line should be no less than half of the phase line section.
  - ⚡ When the phase line is greater than 16 mm<sup>2</sup> and less than or equal to 35mm<sup>2</sup>, the ground line should be consistent with the phase section.
  - ⚡ The section of the ground line must not be less than 16 mm<sup>2</sup>.
- ⚡ The recommended power distribution input wire diameter of the charger should not be less than the following recommended values and should have a separate circuit breaker and leakage. Please see table below:

Charger power(kW)	7	22
Input voltage(V)	230V	400V
Input current(A)	16	32
Recommended line diameter (mm <sup>2</sup> )	10	16

# INSTALLATION



**HYDRA**<sup>®</sup>  
ELECTRIC VEHICLE CHARGERS

## INSTALLATION STEP 1

Screw Type	Quantity to be used (pcs)	Description (use)
Expansion screws, stainless steel M8X10	4	Mounting brackets 1,2 and wall mounting

### Step 1

Confirm the location of the openings in the wall and tap in the expansion screws.

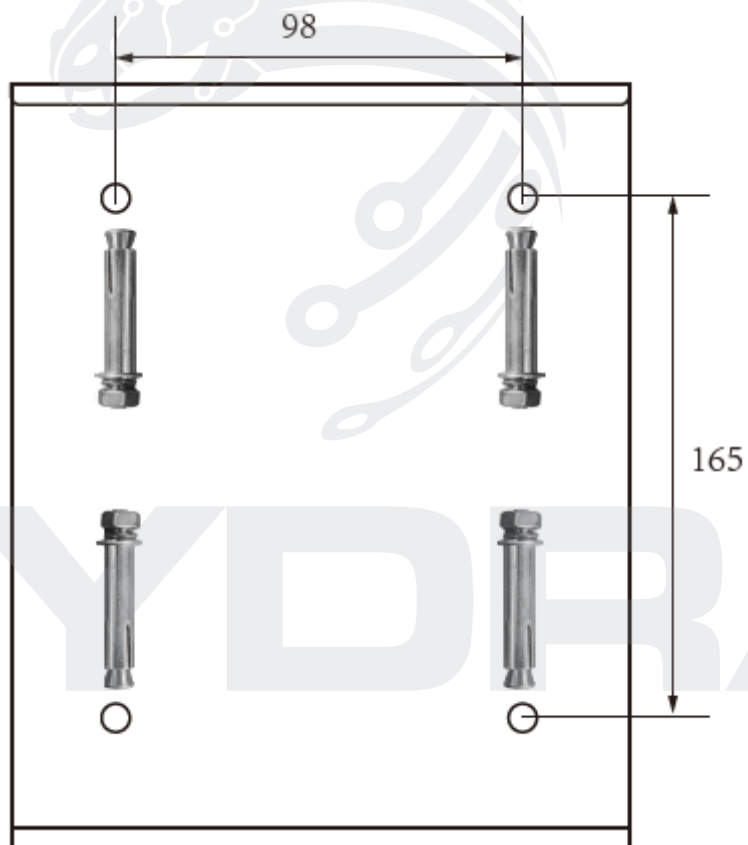

# INSTALLATION



**HYDRA**<sup>®</sup>  
ELECTRIC VEHICLE CHARGERS

## INSTALLATION STEP 2

### Step 2

Pay attention to distinguish the position of the upper and lower mounting brackets, unscrew the expansion screw nut and spacer, align the expansion screw holes, put in the spacer and tighten the nut.

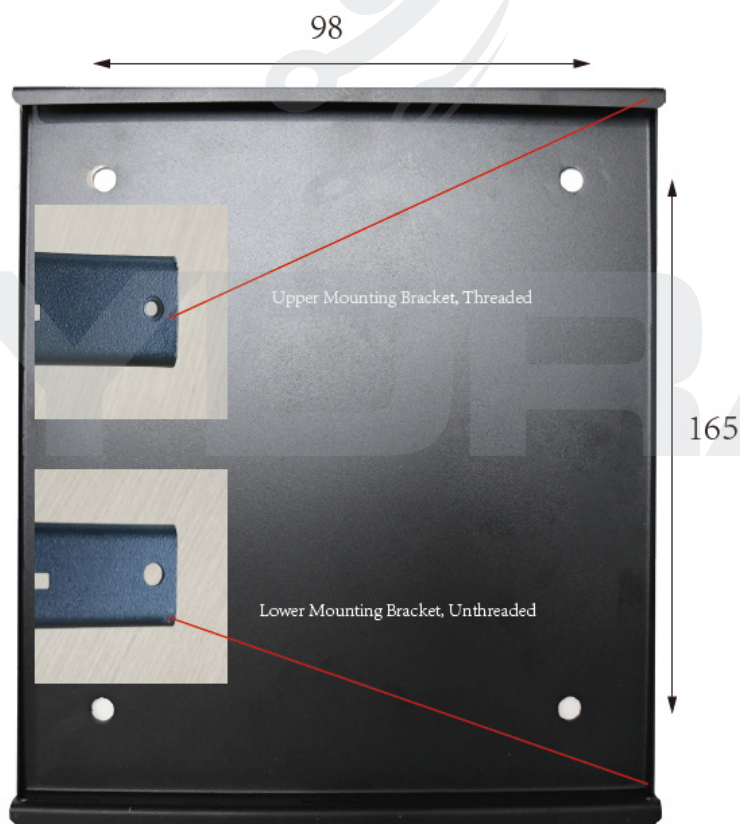

# INSTALLATION



**HYDRA**<sup>®</sup>  
ELECTRIC VEHICLE CHARGERS

## INSTALLATION STEP 3

Screw Type	Quantity to be used (pcs)	Description (use)
Expansion screws, stainless steel M4X10	4	For fixing of the body and mounting bracket

### Step 3

Attach the EV Charging station body to the mounting bracket as shown in the illustration and tighten the four anti-theft screws.



# INSTALLATION



**HYDRA**<sup>®</sup>  
ELECTRIC VEHICLE CHARGERS

## INSTALLATION STEP 4

Step 4

Remove the Anti-Theft screws to open the front door of the EV charging station.

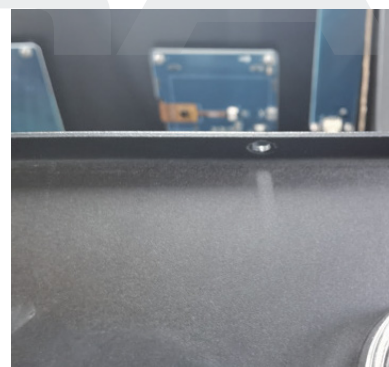



# INSTALLATION



**HYDRA**<sup>®</sup>  
ELECTRIC VEHICLE CHARGERS

## INSTALLATION STEP 5

### Step 5

Wiring needs to meet the following requirements:

1. The charging station should have an independent power distribution circuit and should not be shared with other electrical products.
2. 6mm<sup>2</sup> cable is required at the input end of the 3.5KW/11KW station, 10mm<sup>2</sup> cable is required at the input end of the 7KW and 16mm<sup>2</sup> on a 22KW station, and crimp terminals are required at the input end.
3. In order to prevent electric shock, make sure the input ground is firmly grounded, install according to the installation instructions, and prohibit the use of two-pronged or three-pronged plugs at the front end of the charging station, for which the Division will not be responsible for any consequences.



**Note that in a three-phase 230V power supply environment without N wire, please short the blue N wire and the gray L3 wire L1 brown, L2 black, L3 gray, N blue, PE yellow-green two-color**



Single  
Phase



Three  
Phase



# AFTER-SALES MAINTENANCE



**HYDRA**<sup>®</sup>  
ELECTRIC VEHICLE CHARGERS

## AFTER-SALES SERVICE

- ⚡ Parts are covered by a three-year warranty.
- ⚡ During this period any defective part will be replaced.
- ⚡ One-to-one technical engineer support is available.

## DISCLAIMER

Product equipment must be used under certain conditions. Should the following circumstances lead to an accident or damage, we will not be held responsible.

Opening the door must be carried out in standby mode and, if necessary, the power input needs to be disconnected.

- ⚡ All human factors, damage and use in an abnormal working environment
- ⚡ Failures and damage caused by improperly using the device or not following instructions.
- ⚡ Damage caused by transport after delivery.
- ⚡ Normal wear, breach or immersion.
- ⚡ Use of parts not authorised by the manufacturer (such as aftermarket or counterfeit parts).
- ⚡ Dismantling, repairing or modifying the products without the prior consent of the company.
- ⚡ Damage caused by flood, fire, lightning strike, typhoons, earthquakes or abnormal voltage.
- ⚡ Accidents, faults or damages outside the warranty period.

## MAINTENANCE

### DAILY MAINTENANCE

Regular servicing maintains the charger's safety and condition.

### REGULAR MAINTENANCE

#### MONTHLY

- ⚡ Check the charger is still perfectly upright.
- ⚡ Clean any dirt on the outer surface.
- ⚡ Check for damage to the painted surface.
- ⚡ Test the charging outlets and cables.
- ⚡ Check the LED display status.

#### QUARTERLY

- ⚡ Check the ground screw and ground resistance (no greater than 1Ω).
- ⚡ Check the charger's alarm light is green and the module is working.

# AFTER-SALES MAINTENANCE



**HYDRA**<sup>®</sup>  
ELECTRIC VEHICLE CHARGERS

## MAINTENANCE (CONTINUED)

### SEMI-ANNUALLY

- ⚡ Check ground bolt torque and tighten if required.

### ANNUALLY

- ⚡ Check all internal components.

### ON-SITE MAINTENANCE

This device is an internet of Things-type charger with pre-charge self-test, daily regular self-test, online monitoring of electrical parts and other intelligent functions.

- ⚡ If working, simply perform routine maintenance, no overhaul maintenance is required.
- ⚡ If not working properly, promptly contact the customer service centre or local supplier.

### REMOTE MAINTENANCE

The charger has the function of connecting to the device cloud platform to monitor the status of the charger in real time. When connected, the platform can provide perfect remote diagnosis, remote service and remote upgrade services. It can also locate problems and provide solutions to help the operation centre carry out remote services. It can remotely upgrade software, solve end-user problems and carry out unattended operations.

- ⚡ The system self-tests daily. If there is an issue, it will escalate it automatically.
- ⚡ If there is an abnormal operation, please contact the customer service centre or local supplier promptly.
- ⚡ Service engineers can query logs, update configuration and procedures, carry out remote management, diagnosis, configuration, upgrades and other remote maintenance actions.

# HYDRA

# PROCEDURES



**HYDRA**<sup>®</sup>  
ELECTRIC VEHICLE CHARGERS

## DURING INSTALLATION, REPAIR AND REPLACEMENT OF SPARE PARTS

- ⚡ Live work is strictly prohibited.
- ⚡ Unauthorised dismantling is strictly prohibited.
- ⚡ Follow safety procedures when operating the equipment.
- ⚡ Access to the power supply line should be followed in the PE ground -> zero-line -> phase line order.
- ⚡ All operations must comply strictly with relevant safety standards.

## AFTER INSTALLATION, REPAIR AND REPLACEMENT OF SPARE PARTS

- ⚡ Refer to the installation and maintenance requirements for validation and testing.
- ⚡ Bring your own tools to restore the internal switch.
- ⚡ Lock the safety door for the device to operate safely.

# HYDRA



## FAULT DIAGNOSTICS (CAUSE AND RESOLUTION)

Display status	Potential cause	Recommended solution
The display is black and cannot be illuminated by touch	Charger's AC input is not powered.	Check that the charger input power supply is ok. AC three-phase input voltage should be 240v per phase and line voltage 400v. Check if the input cable is leaking or short-circuited. If the input is fine, try a power-off restart. If the fault is still present, contact our service centre.
Display: splash screen, white screen, cannot display information correctly	Charger runs 24 hours a day, display crashes.	Try a power-off restart. If the fault is still present, contact our service centre.
Display: the charging outlet cannot be locked	The charging connector is not connected to the charging port of the vehicle or the charging connector electronic lock is faulty.	Unplug the charging connector and reconnect. If the fault is still present, contact our service centre.
Display: the charging outlet cannot be unlocked	The charging connector electronic lock is faulty or stuck.	Manually unlock the cable from the charging outlet Contact our service centre.
If none of the above recommendations solve the issue, contact our service centre.		

### End-of-life Disposal

When a product reaches the end of its useful life, or is damaged beyond use for any reason and needs to be scrapped, contact your local council.

### Technical Help

If any issues arise during the installation or you notice any discrepancies with the chargers, please call 01268 205 121 and ask for the Technical Department immediately. If the issue isn't urgent you can email [installs@hydraev.co.uk](mailto:installs@hydraev.co.uk).



# HYDRA



**HYDRA**  
ELECTRIC VEHICLE CHARGERS

**HYDRA EVC Ltd**

Telephone: 01268 205 121

Email: [sales@hydraev.co.uk](mailto:sales@hydraev.co.uk)

Unit 11, Totman Close, Rayleigh, Essex SS6 7UZ