



# HYDRA<sup>®</sup>

**ELECTRIC VEHICLE CHARGERS**



HYDRA<sup>®</sup>

## **GENESIS**

Dual AC EV charger

### **ELECTRIC VEHICLE CHARGER INSTALLATION AND INSTRUCTION MANUAL**

GENESIS-V0002-25.04.2022

# CONTENTS



**HYDRA**<sup>®</sup>  
ELECTRIC VEHICLE CHARGERS

<b>SAFETY</b> .....	<b>3</b>	<b>PLATFORM CONNECTIVITY</b> .....	<b>28</b>
Symbol identification and description .....	3	Connect to the chargecore platform .....	28
Electrical safety.....	4	<b>AFTER-SALES MAINTENANCE</b> .....	<b>29</b>
<b>PRODUCT INTRODUCTION</b> .....	<b>6</b>	After-sales service.....	29
Serial number description .....	6	Disclaimer .....	29
Dimensions.....	7	Maintenance.....	29
Technical Specification.....	8	<b>PROCEDURES</b> .....	<b>31</b>
Product features .....	10	During Installation.....	31
<b>SYSTEM ARCHITECTURE</b> .....	<b>11</b>	After Installation.....	31
<b>INSTALLATION</b> .....	<b>12</b>	<b>APPENDIX</b> .....	<b>32</b>
Internal Structure.....	13	Screen icon identification .....	32
Site Space Requirements .....	14	Fault diagnostics (cause and resolution).....	33
Foundation Requirements.....	15	Genesis electrical diagram .....	34
Electrical Requirements.....	16	Restriction of Hazardous Substances .....	35
Network Connectivity Requirements.....	17	<b>AUTHENTICATION</b> .....	<b>36</b>
Tool Preparation .....	18		
Cabinet Installation Instructions .....	19		
Connecting the power cable .....	20		
Installation instructions .....	13		
<b>COMMISSIONING</b> .....	<b>21</b>		
Operation instructions.....	21		
Power On.....	22		
Charging Operation.....	23		
Non-Operational Flowchart.....	24		
Change Password.....	25		
Setup .....	22		
Commissioning check .....	25		
Switch to Ethernet Mode .....	26		
Using static IP address .....	26		
WiFi Mode .....	26		
4G Mode .....	27		
Set DNS .....	27		
Change URL (OCPP URL) .....	27		



## SAFETY ANNOUNCEMENTS

Before operating the EV charger, read the instructions and precautions carefully to reduce the risk of accidents. The “caution, warning, hazard” notices in the product and product manual do not represent all safety concerns to be observed and are only intended to supplement the various operational safety precautions.

In carrying out the company’s product and equipment operations, you must comply with relevant industry safety norms and strictly abide by these instructions to provide the appropriate equipment precautions and special safety instructions

## IDENTIFICATION DESCRIPTION

	Indicates that care must be taken with the operation or condition of hazardous voltage
	Important security information must be followed very carefully
	Indicates risk of burns from high-temperature areas or areas with high component temperatures
	Ground protected connection point
	DC electricity
	AC electricity
	Indicates that the said action must be performed using clothing and/or personal protective equipment provided by the employer
	Type A Residual Current Devices (RCD)
	Type B Residual Current Devices (RCD)



## ELECTRICAL SAFETY

### HIGH VOLTAGE



Some components of the power system operate with high voltage. Direct or indirect contact with these components through non-insulated protective material poses a fatal hazard.

The installation of AC power supply equipment must comply with safety regulations, and personnel carrying out the installation of AC equipment must be qualified in high voltage AC-power operation.

It is strictly prohibited to wear watches, bracelets, rings or other conductive objects on your wrist or hand.

Turn off the power immediately if you find water or moisture in the electric cabinet. When operating in humid conditions, water should be strictly prevented from entering the equipment.

A "Do not operate" sign must be hung on switches and buttons that are not to be used during installation.



Construction of high-voltage lines can cause fire or electric shock accidents. The racking and wiring of AC cables through the area must comply with the local regulations and specifications. Only personnel qualified for high-voltage and AC operations can carry out various high-voltage operations.

### TOOLS



Special tools must be used for all high AC voltage operations.

### THUNDERSTORMS



High AC voltage operations during thunderstorms are strictly prohibited.

Strong electromagnetic fields are produced in the atmosphere during thunderstorms. To avoid lightning damage to equipment and personnel, do not carry out any operations during thunderstorms.

### ELECTROSTATICS



Static electricity generated by the human body can damage electrostatic-sensitive components on boards such as large-scale integrated circuits (ICs). To prevent static damage to sensitive components, personnel must wear an anti-static bracelet when in contact with equipment (hand-held boards, circuit boards, IC chips, etc.). The anti-static bracelet must be well-grounded on the other end.

# CONTENTS



**HYDRA**<sup>®</sup>  
ELECTRIC VEHICLE CHARGERS

## SHORT CIRCUITS



It is strictly prohibited to short-circuit the power supply system to the positive and negative poles or to short the non-ground pole to ground during operation. Short circuits can cause equipment to burn and pose a personal safety hazard.

In addition, the polarity of the cables and interface terminals must be strictly checked when carrying out live work.

Power distribution operation space is limited. Before any operation, close attention must be paid to the choice of operating space.

An insulation tool must be used during operation.

When working with electricity, care must be taken to keep your hands, wrists and arms steady, to prevent accidents from a tool slipping, or from too much movement of a tool or your body.

## SHARP CORNERS



When moving equipment by hand, wear protective gloves to prevent cuts.

## POWER CABLE



Make sure that the cable label is correct before connecting the cable.

## SIGNAL LINE



The signal cable should be tied separately from the power cable and at least 15mm away.

# INTRODUCTION



**HYDRA**<sup>®</sup>  
ELECTRIC VEHICLE CHARGERS

## SERIAL NUMBER DESCRIPTION

AC002	0722	T1T2	A01	No	ROU0120030002
1	2	3	4	5	6

6	PILE ID NUMBER ROU01 2003 0002 - ROMANIA CUSTOMER LIST 1,2 MARCH 20, PILE 0002
5	FOUNDRY
4	BOM VERSION
3	STANDARD: T2: TYPE2 AC T1: TYPE1 AC GA: GB/T AC C2: CCS2 C1 CCS1 J CHADEMO GD: GB/T DC
2	CHARGING POWER: TYPE2 AC PILE RATED POWER 22KW CCS2 PILE RATED POWER 40KW CHADEMO PILE RATED POWER 20KW
1	PRODUCT MODEL: AC001- PLASTIC HOUSING 1 AC PILE AC002- METAL COLUMN AC PILE AC003- ALUMINUM AC PILE AC004- PLASTIC HOUSING 2 AC PILE AC005- METAL SHELL AC PILE AC006- POLYCARBONATE REINFORCED ABS AC PILE PAC- ADVERTISING AC PILE

The Genesis has a dual connector output of 2x7/22/43kW function. Dual outlets can be configured at the same time or in combination with Type 1 J1772, Type 2 and Mennekes connectors. The system can be installed outdoors (but for safety reasons, if the water level reaches the charger connector, it should not be used in rainy or snowy conditions).

# INTRODUCTION



**HYDRA**<sup>®</sup>  
ELECTRIC VEHICLE CHARGERS

## APPEARANCE & DIMENSIONS

Use	Car Parks / Public Charging Station
Material	Metal housing
Installation type	Floor Stand
Cable layout	Bottom
Weight	53kg
Cable length	≥4.2m (External Line)
Charging socket	Type1 & Type1 or Type2 & Type2 or Type1 & Type2

- 1 Touch Screen
- 2 RFID Card Reader
- 3 LED Indicators
- 4 Charging Cable Dock (x 2)
- 5 Charging Cable Holder
- 6 Contactless Payment Module *(option)*



7

# INTRODUCTION



**HYDRA**<sup>®</sup>  
ELECTRIC VEHICLE CHARGERS

## TECHNICAL SPECIFICATIONS

COMPONENT SPECIFICATIONS	Dimensions	280(W) x 190(L) x 1500(H)* mm *TBC
	Weight	53kg (including cable)
	Cable length	≥4.2m/SOCKET
	Shell material	Sheet metal
	Screen	5" LCD touch screen
POWER CHARACTERISTICS	Input voltage	TN-S 240V AC (single phase) 400V AC (three phase) ±10%
	Input frequency	50hz/60hz
	Rated power	7kW (single phase) 22kW/43kW (three phase)
	Measurement accuracy	≤±0.5%
	Output voltage	Same as input voltage
	Output current	7kW/22kW-32A, 43kW-63A
	Efficiency	≥94%
	Factor	≥0.99
DESIGN FEATURES	UI	RFID Card Reader, LCD touch screen
	Standard	GB/T, TYPE1 J1772, TYPE2 and IEC61851-1/2017
COMMUNICATION	Web interface	Wired Ethernet, Wi-Fi, 3G/4G
	OCPP	OCPP 1.6J



# INTRODUCTION



**HYDRA**<sup>®</sup>  
ELECTRIC VEHICLE CHARGERS

## TECHNICAL SPECIFICATIONS (CONTINUED)

WORKING ENVIRONMENT	Use	Indoor/Outdoor
	Operating temperature	-30°C ~ +55°C
	Operating humidity	5% to 95%
	Elevation	<2000m
	Protection level	IP55
	Cooling method	Ambient air cooling
	Ground detection	30mA AC, 6mA DC
	Sound level	≤50db (normal input/output power at ambient 25°C)
	RoHS	Meets the R5 requirements of the RoHS directive

**HYDRA**<sup>®</sup>

# CONTENTS



**HYDRA**<sup>®</sup>  
ELECTRIC VEHICLE CHARGERS

## PRODUCT FEATURES

The HYDRA GENESIS Dual AC Charger has a modern design and user-friendly interface, designed for domestic and workplace use.

### SAFETY FEATURES

- ⚡ Hardware protection features:
  - ⚡ Overcurrent protection
  - ⚡ Overvoltage protection
  - ⚡ Over-temperature protection
  - ⚡ Lightning protection
  - ⚡ Type B RCD
- ⚡ Comprehensive software protection features, providing multiple protections
- ⚡ Meets IEC61851-22 requirements
- ⚡ All components have CE certificates
- ⚡ The SECC controller has gone through the TÜV test

### SMART

- ⚡ The terminal charger is connected to the Open Charge Point Protocol platform online
- ⚡ Remote diagnostics, remote upgrades
- ⚡ Compatible with GB/T, Type1-SAEJ1772, Type 2 and IEC61851-1/2017
- ⚡ Internal high-precision MID AC meter
- ⚡ Supports simultaneous charging of multiple connectors
- ⚡ The OCPP platform sets the maximum output power according to the time period
- ⚡ Support for credit card Point Of Sale payment (optional)
- ⚡ Support for OCPP1.6-J (later direct upgrade to 2.0)

### CONVENIENT

- ⚡ Wireless or wired communication, flexible networking
- ⚡ Open communication protocol for sweep charge, swipe charging and API services
- ⚡ Several settings to end the charge
  - ⚡ Time limit
  - ⚡ Amount of electricity

### OPTIONAL FEATURES

- ⚡ Plug&Charge (optional)

# SYSTEM ARCHITECTURE



**HYDRA**<sup>®</sup>  
ELECTRIC VEHICLE CHARGERS

## ELECTRIC

Transformer - Switch - Charger - Car

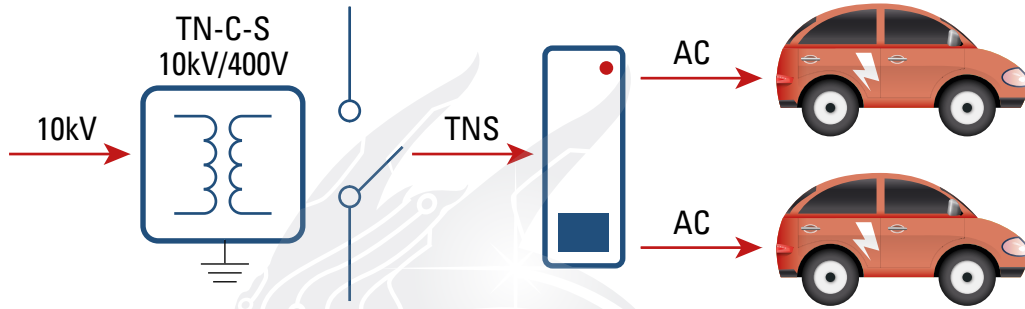

## INTERNAL SYSTEM COMMUNICATIONS

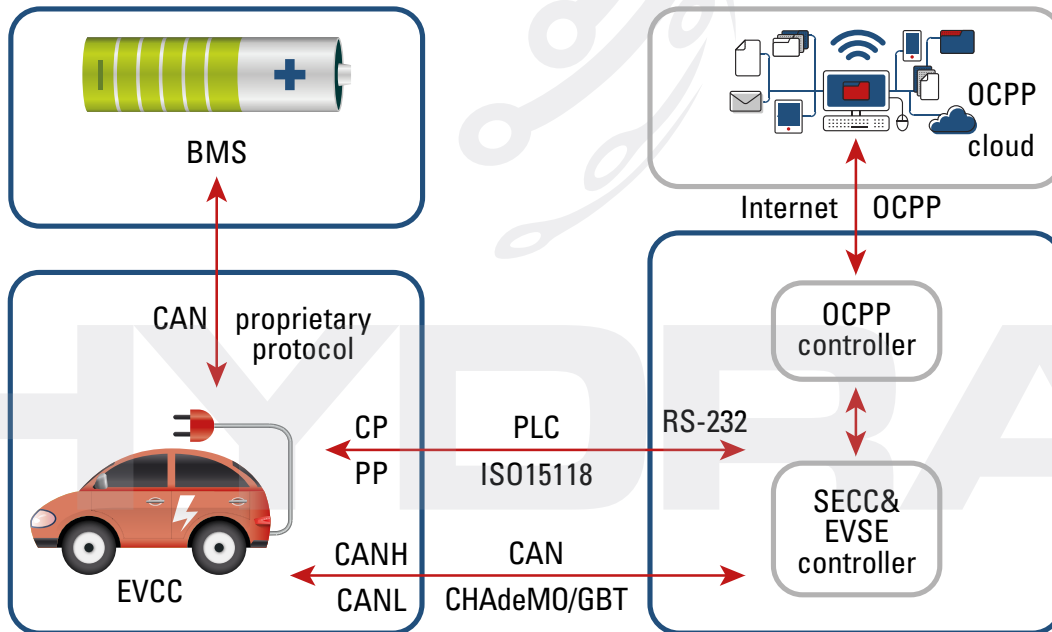

# INSTALLATION



**HYDRA**<sup>®</sup>  
ELECTRIC VEHICLE CHARGERS

## PROCEDURE

### SAFETY INSTRUCTIONS

The operating voltage and current inside the charging system are high, and the following regulations should be observed at all times to ensure personal safety:

1. Charging systems must only be installed by personnel who have been trained in, and have sufficient knowledge of, the charging system. Always follow safety precautions and local safety regulations during installation.
2. To operate inside the charging system, make sure that the charging system is not live. The power input to the charging system must be disconnected.
3. Distribution cable wiring should be reasonable and protective to avoid accidental contact when operating power supplies.

### VISUAL INSPECTION

Upon product delivery, check that the package is not damaged and that the label is complete and correct. If there is an issue, immediately inform the carrier and take photos as evidence. At the same time, immediately contact the manufacturer to discuss the issue.

Only after the goods arrive at the installation site can they be opened and the boxes opened for inspection. Start by opening the box with the packing slip, taking out the packing list and checking it against each item. Next, check the serial number of the box, the equipment packaging, the number and type of accessories and the integrity of all items.

Following the packing list, check that accessories and accompanying documents are complete (refer to the shipping list) and store the accessories and documents properly.

Carry out a visual inspection to ensure that the product is free of abnormal marks showing collisions, and of scratches, cracks, dents, rust, breakage, or peeling of paint.

Sign receipt documents, make a record of the situation, keep documents and scan them for archives, or give them to relevant parties.

### ACCESSORY LIST

The packing list comes with the shipping documents.

# INSTALLATION



**HYDRA**<sup>®</sup>  
ELECTRIC VEHICLE CHARGERS

## INTERNAL STRUCTURE

- 1 Touch screen
- 2 RFID card reader
- 3 LED indicator lights
- 4 OCPP
- 5 Door locks
- 6 MID Relay x 2
- 7 Auxiliary power supply
- 8 MID Meter x 2
- 9 Contactor x 2
- 10 Type B RCD x 2
- 11 Power cable

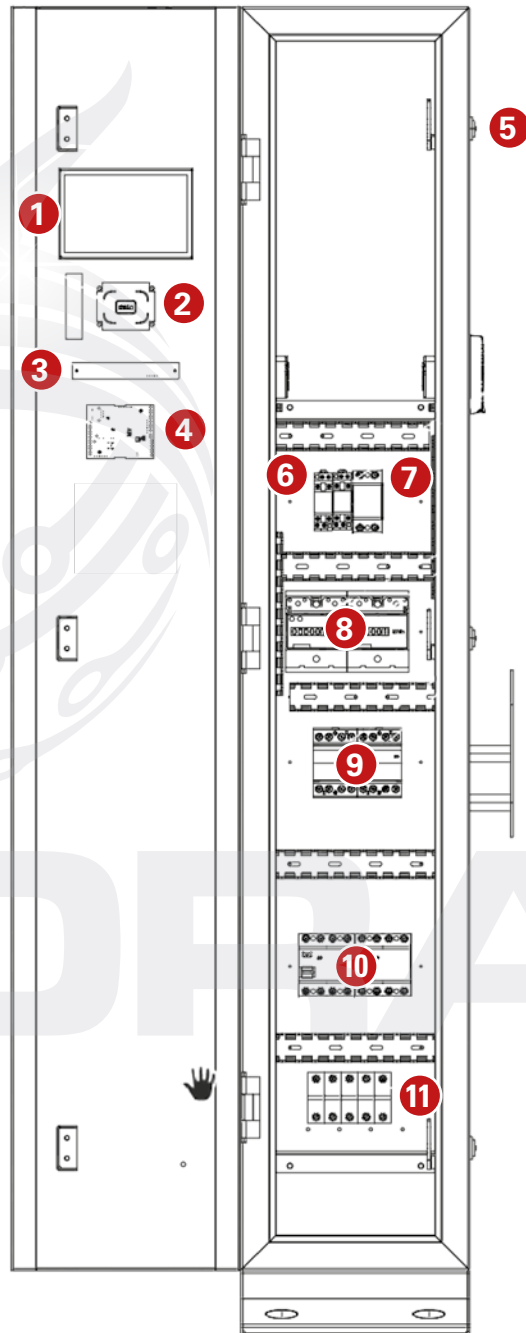

# INSTALLATION



**HYDRA**<sup>®</sup>  
ELECTRIC VEHICLE CHARGERS

## SITE SPACE REQUIREMENTS

Adequate installation space should be reserved to ensure safe and reliable operation, ventilation and maintenance of the equipment.

Installation requires 1386 x 900 mm of space, calculated as follows:

Product size: 400(L) X 386(W) X 1500(H) , excluding cable hangers and accessories.

Front reserved spacing  $\geq 400$ mm to ensure the front door open/close operation is normal and all related operations are unhindered.

- ⚡ Left reserved spacing  $\geq 500$ mm to ensure operating space.
- ⚡ Right-hand reserved spacing  $\geq 500$ mm to ensure operating space.
- ⚡ Rear reserved spacing  $\geq 100$ mm to ensure operating space.

Dimensions (from above)

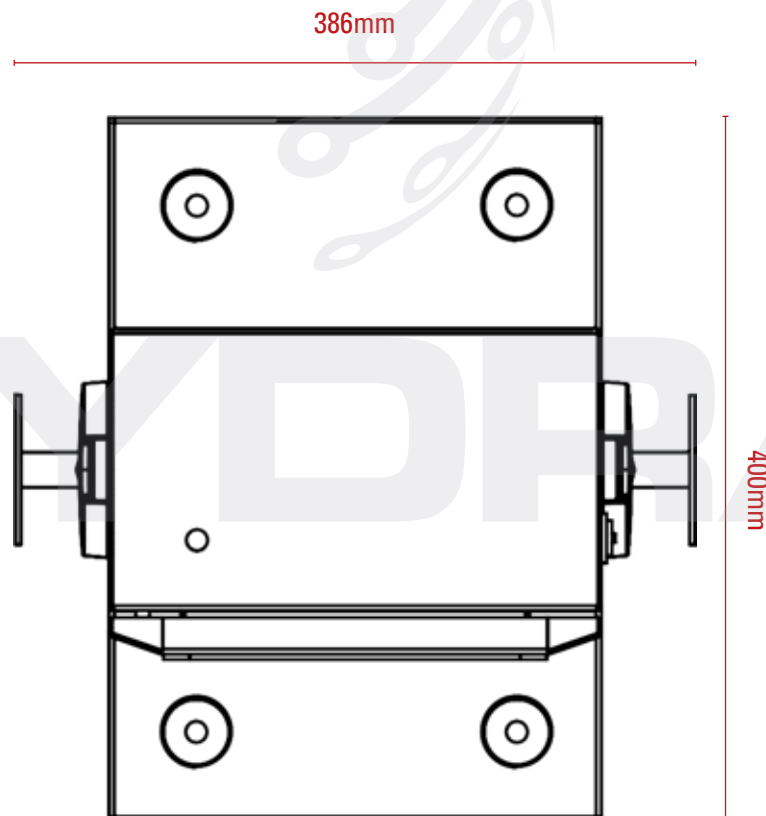



## FOUNDATION REQUIREMENTS

A dedicated foundation is not necessary when the equipment is installed indoors or in higher and drier sites, but the ground level plan error per square meter must not exceed  $\pm 1.5\text{mm}$ , and the ground strength level of the installation position must not be less than C30. When the equipment is installed outdoors and in low-lying, damp or potentially humid environments, a cement or slot steel base must be installed. The cement base must be 200mm above the ground (the recommended height below the ground is not less than 500mm). The mounting surface requires four pre-buried M6 stainless steel bolts, bolt thread exposed to the ground  $30\pm 3\text{mm}$ .

The cable wire enters through the bottom of the charger through an inlet hole.

- ⚡ On the ground where the charger is to be installed, dig a hole not smaller than the base dimensions indicated in the figure below.
- ⚡ Make sure that the cable is accessible from the pre-buried pipe.
- ⚡ Pour the concrete into the concrete foundation shown in the figure below.
- ⚡ It is recommended that the base of the charger be at least 200mm above the ground, effectively reducing the risk of flooding.
- ⚡ Reserve a cable length of 1m above the base for internal wiring.
- ⚡ Fill the inside and outside of the base with sand and stone. The inlet holes may need to be blocked to prevent small animals such as rats from entering the equipment.

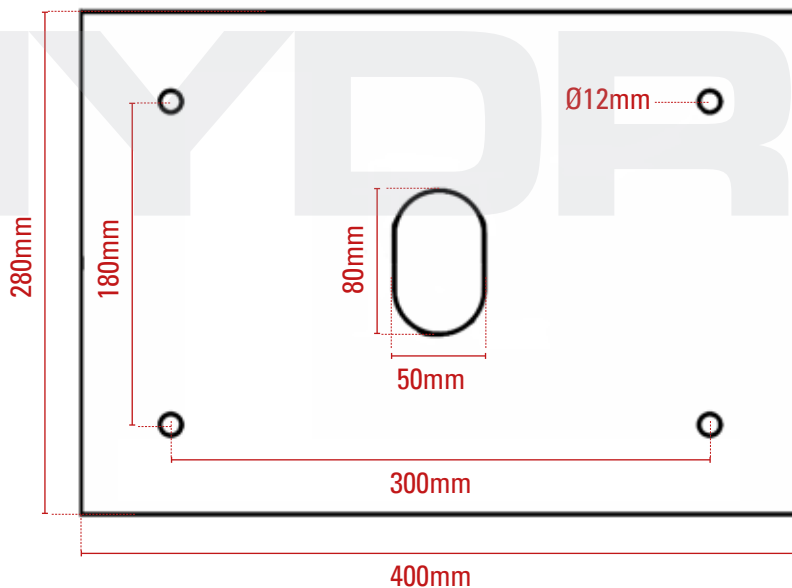



## ELECTRICAL REQUIREMENTS

Cable type: Three-phase, five-wire (TN-C-S/TN-S) confirming the need for shielding as required by local laws or norms

- ⚡ If there is a shield, both ends of the shield are connected to the PE secure ground.
- ⚡ Cable diameter requirements are determined by the contractor or electrical engineer, based on power, distance and industry standards, or the following recommendations:
  - ⚡ ZR-YJV-multi-core-sheath power cable.
  - ⚡ The voltage level is 450/750V or higher.
  - ⚡ A temperature of at least 90°C should be achieved.
- ⚡ PE Safety ground wire requires the same size model as the N wire, or uses the following recommended requirements:
  - ⚡ When the phase line is greater than 35 mm<sup>2</sup>, the ground line should be no less than half of the phase line section.
  - ⚡ When the phase line is greater than 16 mm<sup>2</sup> and less than or equal to 35mm<sup>2</sup>, the ground line should be consistent with the phase section.
  - ⚡ The section of the ground line must not be less than 16 mm<sup>2</sup>.
- ⚡ The recommended power distribution input wire diameter of the charger should not be less than the following recommended values and should have a separate circuit breaker and leakage (the following table is at 25 environment, YJV22 (armoured) cable in the soil directly applying flow as a reference, according to the actual cable material and laying method to determine the specific wire diameter).

Charger power(kW)	7x2	7+22	7+43	22x2	22+43	43x2
Input voltage(V)	230V	400V				
Input current(A)	32+32	32+32	32+64	32+32	32+64	64x2
Recommended line diameter (mm <sup>2</sup> )	10	10	25	10	25	35



# INSTALLATION



**HYDRA**<sup>®</sup>  
ELECTRIC VEHICLE CHARGERS

## NETWORK CONNECTIVITY REQUIREMENTS

The recommended way to connect to the network is to access 4G wireless communication or a Wi-Fi module integrated in the charger. A SIM card meeting local networking requirements is required. Make sure the local signal strength is strong and stable; otherwise a signal amplifier must be installed.

If there is no local 3G/4G communication signal, a standard wired internet connection is available. Wired connections must meet the following requirements:

- 🔌 RJ45 Ethernet
- 🔌 Network cable type: 5e class or greater, 8P plus PE, shielding wire.
- 🔌 It is recommended that the line length is less than 75m. Greater than 75m length requires a customised engineering solution.
  
- 🔌 Minimum bandwidth required:
  - 🔌 Upstream: 128 kbps
  - 🔌 Downstream: 4 Mbps
  
- 🔌 Demand connection reliability: 99.9%.
  
- 🔌 For special configurations, please contact us.

**HYDRA**<sup>®</sup>

# INSTALLATION



**HYDRA**<sup>®</sup>  
ELECTRIC VEHICLE CHARGERS

## TOOL PREPARATION

### STANDARD TOOLS

NAME	DESCRIPTION	QTY
Multimeter	Checking the electrical connections and electrical parameters	1
Electric impact drill	Drilling	1
Impact drill bit (Ø 14mm)	Drilling	2
Tape measure (5m)	Measurement	1
Level ruler	Measurement	1
Crosshead screwdriver	Unpacking	1
Pliers	Unpacking	1
Wire Stripper	Removing the insulation sheath / jacket	1
Terminal pressure line pliers	Pressing the terminals	1
Bevel cutting pliers	Cutting the cable	1
Light hammer	Unpacking, tapping, adjustment	1
Carrying equipment	Moving and hoisting charger	1
PVC tape and sheath	Insulation tape and insulation cladding connection	1
Personal protection tools	Ensuring the health and safety of operators	1

**HYDRA**<sup>®</sup>

# INSTALLATION



**HYDRA**<sup>®</sup>  
ELECTRIC VEHICLE CHARGERS

## CABINET INSTALLATION INSTRUCTIONS

### TRANSFER LOADING AND UNLOADING

- ⚡ Lifting and moving the charger must be carried out by trade professionals using a dedicated load-bearing forklift/crane or other professional load-bearing transfer device.
- ⚡ Do not drop or hit the device.
- ⚡ Move the equipment to a pre-made concrete base and lift the charger into place with a lifting device.

### INSTALLATION

- ⚡ Place the cabinet on the base
- ⚡ Secure the cabinet to the base.
- ⚡ Carefully and slowly lower the charger into place.
- ⚡ Make sure that the cable has been passed into the cabinet along the seal sleeve.
- ⚡ Ensure that the cabinet holes and bolts are aligned.
- ⚡ Insert flat washers, gaskets and nuts at the four corners and front and rear sides.
- ⚡ Lock these nuts to 95.5 Nm.
- ⚡ Keep the device upright – do not tilt more than  $\pm 15$  degrees.



# INSTALLATION



**HYDRA**<sup>®</sup>  
ELECTRIC VEHICLE CHARGERS

## CONNECT THE POWER CABLE

**Note:** Turn off switches and pull out all fuses before connecting electrically

### CONNECT THE GROUND CABLE

The charging system uses a common grounding method, using a ground cable to connect the ground copper row of the charging cabinet with the main ground row.

### CONNECT THE AC INPUT

1. The AC input cable is routed from the user's power distribution switch and is connected to the output terminal of the user switch when power is ready to be turned on. The user distribution switch should have overcurrent, short circuit, lightning strike and other protective devices. The capacity of the power distribution switch is recommended as not less than 1.5 times the actual load capacity.
2. The L1-phase, L2-phase, L3-phase and N-zero cables of the AC input cable should use brown, black, grey and blue cables (standard reference below). If the cable has only one colour, the line number identification is pasted or marked with different colour insulation at both ends of the cable.
3. Cables should not have severed heads, broken heads or scratches.

Colour	Brown	Black	Grey	Blue	Yellow & Green
Phase order	A(L1)	B(L2)	C(L3)	N	PE

The AC input can be introduced from the bottom of the cabinet through a trench and connected sequentially to the corresponding terminal.

### PHASE LINE / ZERO STUD / IDENTIFICATION CHART



**PLEASE NOTE:** Wiring Lugs or Crimp Terminals are not supplied with the Hydra Genesis



## CHECK BEFORE COMMISSIONING

Before starting commissioning work, the following conditions need to be prepared and validated:

- ⚡ All preparation, installation, connections, etc. have been completed.
- ⚡ The charger input power supply has been connected and the charger power-up capacity is already available.
- ⚡ If there is no 3G/4G signal, the network needs to be connected via a wired network.
- ⚡ The site must be staffed by a full-time security officer for safety supervision.
- ⚡ Arrange the operation representative and accept the on-site guidance of the charging operation.

## POWER-ON CHECK

- ⚡ Once the charger is connected to AC power, check for fault alarms on the LED display and check the charging module is working properly. Configure the network information, check the network connection status and signal strength.

## CHARGING OPERATION

- ⚡ Connect an electric car or test device. The charger must show that the electric vehicle is connected.
- ⚡ Swipe the RFID card or use the App to start charging and check the charger starts normally.
- ⚡ Check the charger's alarm light is green and the module is working.

## POWER-ON PROCESS

After ensuring that the charger installation is complete, the wiring is accurate, and the overall commissioning is complete, the charger can be powered on.

Confirm that AC circuit breakers and contactors are disconnected and switch on the AC feed. The charger should not emit an alarm or show an abnormal state signal.

The closed AC circuit breaker, other switching devices and the charger screen and indicators should be illuminated. The interface shows the door alarm, fault indicator on, indicating that the access control system is working normally.

Check that the components are working properly and close the doors. The fault indicator should turn off.

# COMMISSIONING



# HYDRA<sup>®</sup>

ELECTRIC VEHICLE CHARGERS

## SWITCH CHART



## POWER ON STANDBY FLOWCHART



1 Boot up



2 Power On Self Test



3 When connected to the internet



4 OCPP connected



## CHARGING OPERATION

Charging can be carried out in two ways: card-free charging (code scanning, app) and card charging (IC card, POS machine) (optional).

Click on the Charger information to obtain the charger output capacity and operating status information. Note that the charger cannot charge a vehicle if there is an alert showing on the charger. Charges are required after troubleshooting against the fault identification or fault code.

In the charging mode interface, you can choose to charge automatically, by time, by charge, by amount and by percentage.

When the set value is reached or the vehicle issues a stop command, the charger stops charging automatically.

## CHARGING OPERATION FLOWCHART

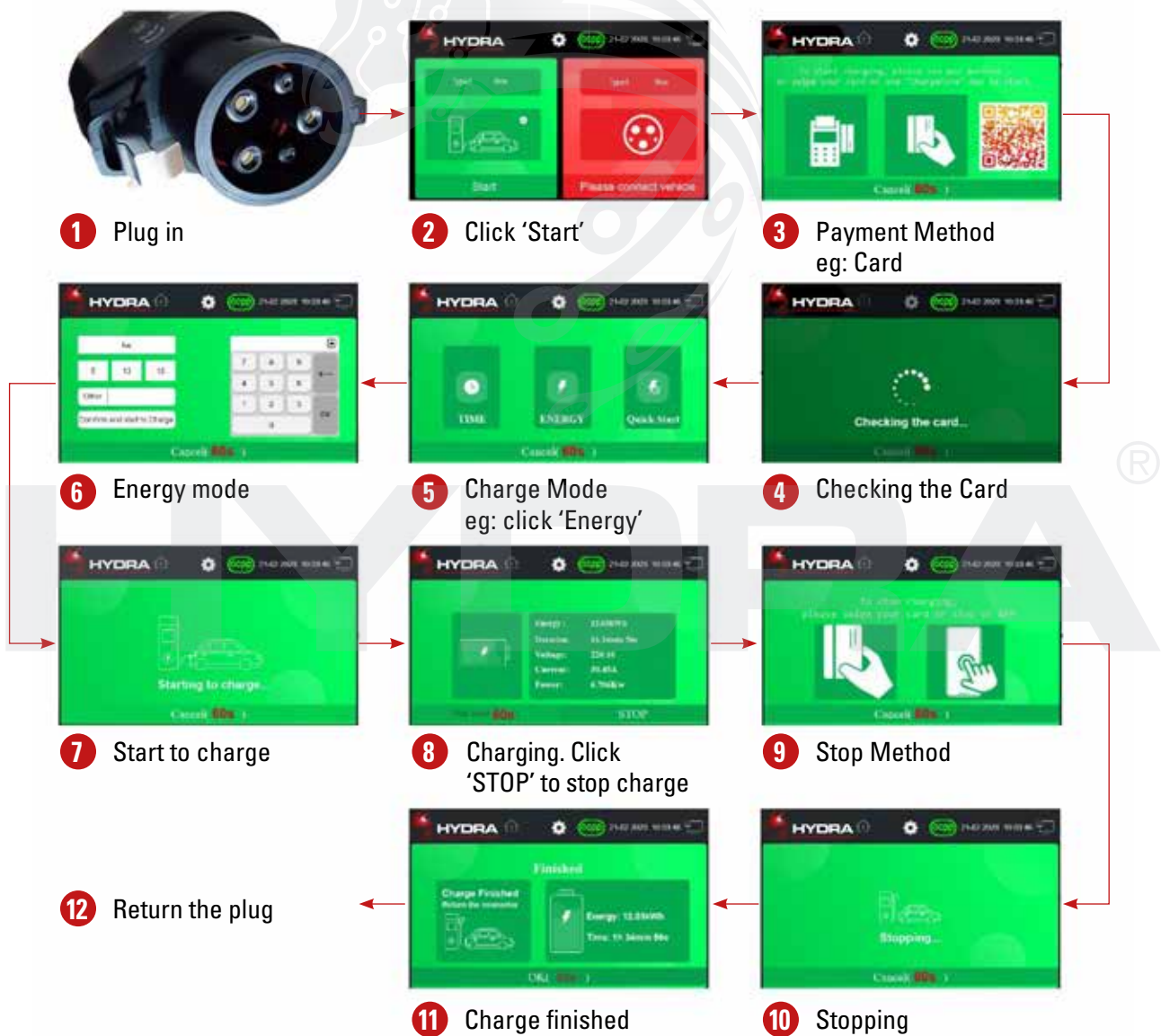

# COMMISSIONING



**HYDRA**<sup>®</sup>  
ELECTRIC VEHICLE CHARGERS

## NON-OPERATIONAL MODE FLOWCHART

CLICK 'CONFIRM' TO COMPLETE SETUP



1 Click on this icon

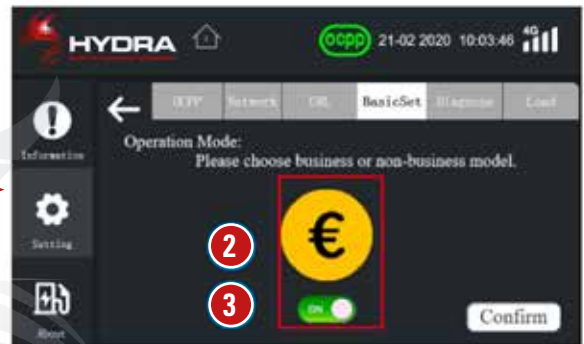

2 Click this button to change the mode

3 'ON' = Business use



6 Set successfully and automatically return to the BASIC SET menu



4 The current mode 'Non-Business'

5 Click 'Confirm' to complete the change

## FORCED UNPLUGGING & RECOVERY

Forced unplugging of the charging outlet is prohibited during charging!





## SETUP

### CHANGE PASSWORD



- 1 Input old password
- 2 Input new password
- 3 Re-enter the password to confirm
- 4 Click 'Confirm' to complete the change
- 5 Cancel the password change
- 6 Password changed successfully  
Displays New Password

# HYDRA<sup>®</sup>



## SWITCH TO ETHERNET MODE: AUTOMATIC MODE



- 1 The current mode: Automatic
- 2 Click 'Connect'
- 3 Loading ...
- 4 Setting successfully
- 5 Ethernet icon

## USING STATIC IP ADDRESS MODE

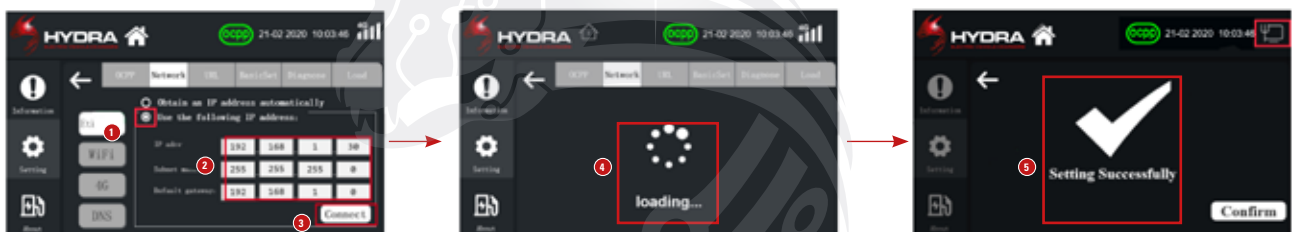

- 1 Use static IP addresses mode
- 2 Enter the IP address
- 3 Click 'Connect'
- 4 Loading ...
- 5 Setting successfully
- 6 Ethernet icon

## SWITCH TO WIFI MODE

IF THE WIFI LIST IS EMPTY, PLEASE REFRESH THE WIFI NETWORK LIST FIRST



- 1 Refresh the WIFI list first
- 2 Scan
- 3 Choose a WIFI network



- 4 Enter password
- 5 Click 'next' to connect to WIFI
- 6 Setting successfully
- 7 WIFI icon

# COMMISSIONING



**HYDRA**<sup>®</sup>  
ELECTRIC VEHICLE CHARGERS

## SWITCH TO 4G MODE



- 1 The current mode: Ethernet
- 2 Click '4G' to switch to 4G mode
- 3 Click 'OK'
- 4 Setting successfully
- 5 4G icon

## SET DNS

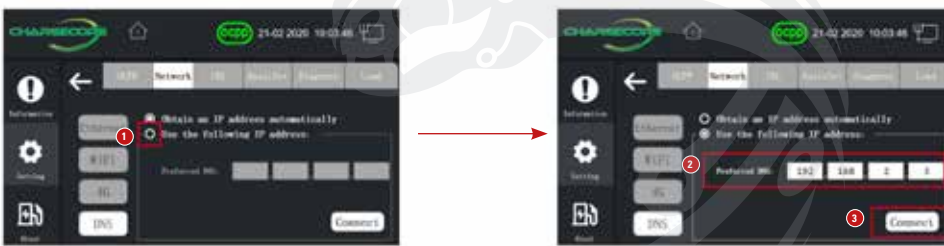

- 1 Click 'Use the following IP address:'
- 2 Input DNS:
- 3 Click 'Connect'

## CHANGE THE URL

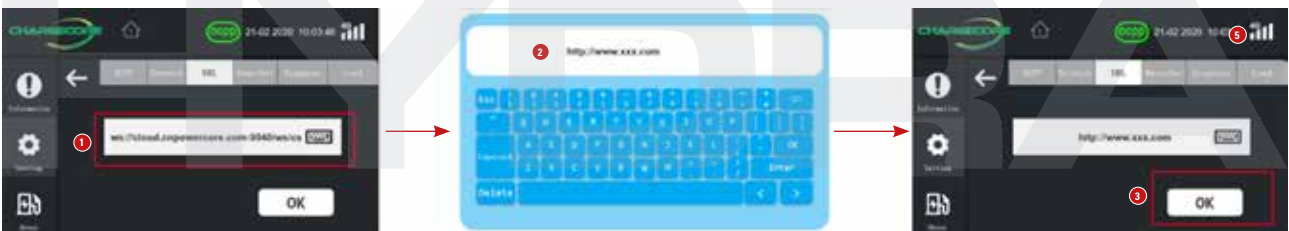

- 1 Click on the input box
- 2 Input new URL
- 3 Click 'OK'

# PLATFORM CONNECTIVITY



**HYDRA**<sup>®</sup>  
ELECTRIC VEHICLE CHARGERS

## CONNECT TO THE CHARGECORE PLATFORM

When connected to the online Chargecore platform, the charger can perform remote management, diagnosis, configuration, maintenance, upgrades and other functions.

Chargecore platform data interaction diagram

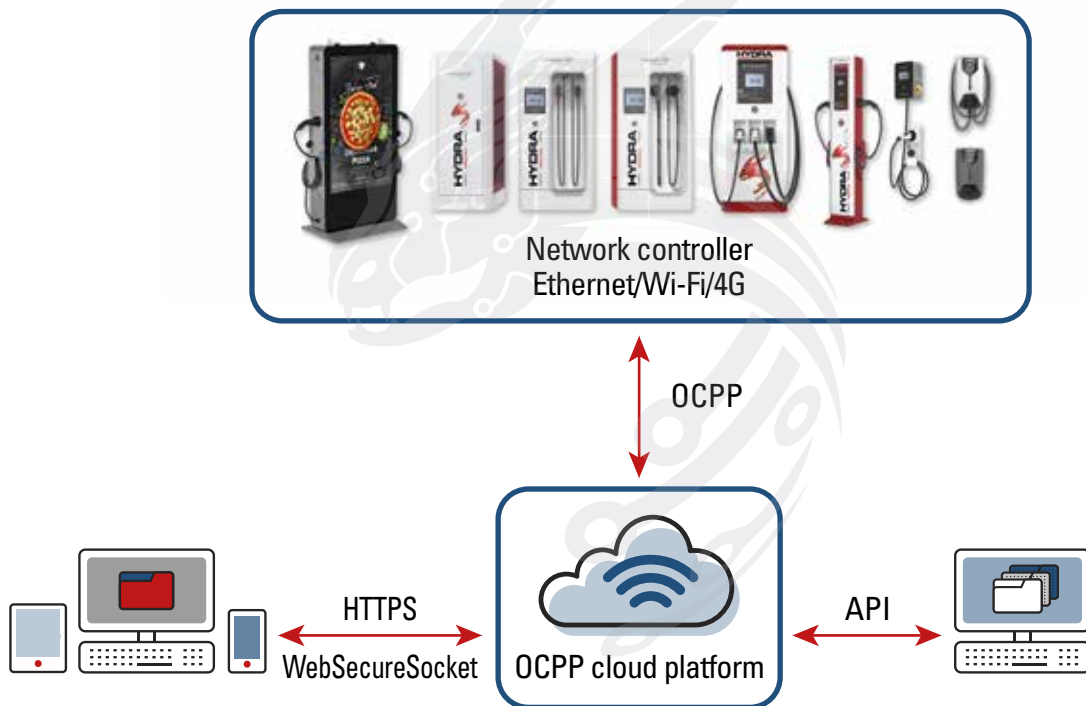

### CONNECTION OPERATION

For connection to platform operations, your on-site installer should be able to assist or alternatively contact Hydra EVC Ltd.

Hydra charger support connects customers through OCPP protocol with the existing operating platform. Please contact the Chargecore Sales or Service Engineer.

# AFTER-SALES MAINTENANCE



**HYDRA**<sup>®</sup>  
ELECTRIC VEHICLE CHARGERS

## AFTER-SALES SERVICE

- ⚡ Parts are covered by a three-year warranty.
- ⚡ During this period any defective part will be replaced.
- ⚡ One-to-one technical engineer support is available.

## DISCLAIMER

Product equipment must be used under certain conditions. Should the following circumstances lead to an accident or damage, we will not be held responsible.

Opening the door must be carried out in standby mode and, if necessary, the power input needs to be disconnected.

- ⚡ All human factors, damage and use in an abnormal working environment
- ⚡ Failures and damage caused by improperly using the device or not following instructions.
- ⚡ Damage caused by transport after delivery.
- ⚡ Normal wear, breach or immersion.
- ⚡ Use of parts not authorised by the manufacturer (such as aftermarket or counterfeit parts).
- ⚡ Dismantling, repairing or modifying the products without the prior consent of the company.
- ⚡ Damage caused by flood, fire, lightning strike, typhoons, earthquakes or abnormal voltage.
- ⚡ Accidents, faults or damages outside the warranty period.

## MAINTENANCE

### DAILY MAINTENANCE

Regular servicing maintains the charger's safety and condition.

### REGULAR MAINTENANCE

#### MONTHLY

- ⚡ Check the charger is still perfectly upright.
- ⚡ Clean any dirt on the outer surface.
- ⚡ Check for damage to the painted surface.
- ⚡ Test the charging outlets and cables.
- ⚡ Check the LED display status.

#### QUARTERLY

- ⚡ Check the ground screw and ground resistance (no greater than 1Ω).
- ⚡ Check the charger's alarm light is green and the module is working.

# AFTER-SALES MAINTENANCE



**HYDRA**<sup>®</sup>  
ELECTRIC VEHICLE CHARGERS

## MAINTENANCE (CONTINUED)

### SEMI-ANNUALLY

- ⚡ Check ground bolt torque and tighten if required.

### ANNUALLY

- ⚡ Check all internal components.

### ON-SITE MAINTENANCE

This device is an internet of Things-type charger with pre-charge self-test, daily regular self-test, online monitoring of electrical parts and other intelligent functions.

- ⚡ If working, simply perform routine maintenance, no overhaul maintenance is required.
- ⚡ If not working properly, promptly contact the customer service centre or local supplier.

### REMOTE MAINTENANCE

The charger has the function of connecting to the device cloud platform to monitor the status of the charger in real time. When connected, the platform can provide perfect remote diagnosis, remote service and remote upgrade services. It can also locate problems and provide solutions to help the operation centre carry out remote services. It can remotely upgrade software, solve end-user problems and carry out unattended operations.

- ⚡ The system self-tests daily. If there is an issue, it will escalate it automatically.
- ⚡ If there is an abnormal operation, please contact the customer service centre or local supplier promptly.
- ⚡ Service engineers can query logs, update configuration and procedures, carry out remote management, diagnosis, configuration, upgrades and other remote maintenance actions.

# HYDRA

<sup>®</sup>

# PROCEDURES



**HYDRA**<sup>®</sup>  
ELECTRIC VEHICLE CHARGERS

## DURING INSTALLATION, REPAIR AND REPLACEMENT OF SPARE PARTS

- ⚡ Live work is strictly prohibited.
- ⚡ Unauthorised dismantling is strictly prohibited.
- ⚡ Follow safety procedures when operating the equipment.
- ⚡ Access to the power supply line should be followed in the PE ground -> zero-line -> phase line order.
- ⚡ All operations must comply strictly with relevant safety standards.

## AFTER INSTALLATION, REPAIR AND REPLACEMENT OF SPARE PARTS

- ⚡ Refer to the installation and maintenance requirements for validation and testing.
- ⚡ Bring your own tools to restore the internal switch.
- ⚡ Lock the safety door for the device to operate safely.

**HYDRA**<sup>®</sup>

# APPENDIX



**HYDRA**<sup>®</sup>  
ELECTRIC VEHICLE CHARGERS

## SCREEN ICON KEY

	Logo		The connector is not inserted
	Power on Progress bar		Plugged in
SOC Unit: %	Charging mode selection: SoC, % per unit		Charged
	Charging (animation)		Charge completed
	Loading (animation)		Charging has been booked
	OCPP connected		Fault during charging
	OCPP connected		Charging outlet not available
	Wired network not connected		Billing charged upon charging
	Wired network connection		The screen is being heated due to ultra-low ambient temperature
	Wired network connected		The screen is not being heated
	Wi-Fi not connected	<b>Type2</b>	European AC standard
	Wi-Fi connected	<b>GBT/AC</b>	Chinese AC standard
	4G not connected	<b>Type1</b>	U.S. AC standard
	4G connected		Error, go to the administrator interface to see the fault
	No fault		Enable operation mode to save each charging record
	Issue detected		Enable operating mode, no charging records



# CONTENTS



**HYDRA**<sup>®</sup>  
ELECTRIC VEHICLE CHARGERS

## FAULT DIAGNOSTICS (CAUSE AND RESOLUTION)

Display status	Potential cause	Recommended solution
The display is black and cannot be illuminated by touch	Charger's ac input is not powered.	Check that the charger input power supply is ok. AC three-phase input voltage should be 240v per phase and line voltage 400v. Check if the input cable is leaking or short-circuited. If the input is fine, try a power-off restart. If the fault is still present, contact our service centre.
Display: splash screen, white screen, cannot display information correctly	Charger runs 24 hours a day, display crashes.	Try a power-off restart. If the fault is still present, contact our service centre.
Display: the charging outlet cannot be locked	The charging connector is not connected to the charging port of the vehicle or the charging connector electronic lock is faulty.	Unplug the charging connector and reconnect. If the fault is still present, contact our service centre.
Display: the charging outlet cannot be unlocked	The charging connector electronic lock is faulty or stuck.	Manually unlock the cable from the charging outlet Contact our service centre.
If none of the above recommendations solve the issue, contact our service centre.		

**HYDRA**<sup>®</sup>



## ELECTRICAL DIAGRAM

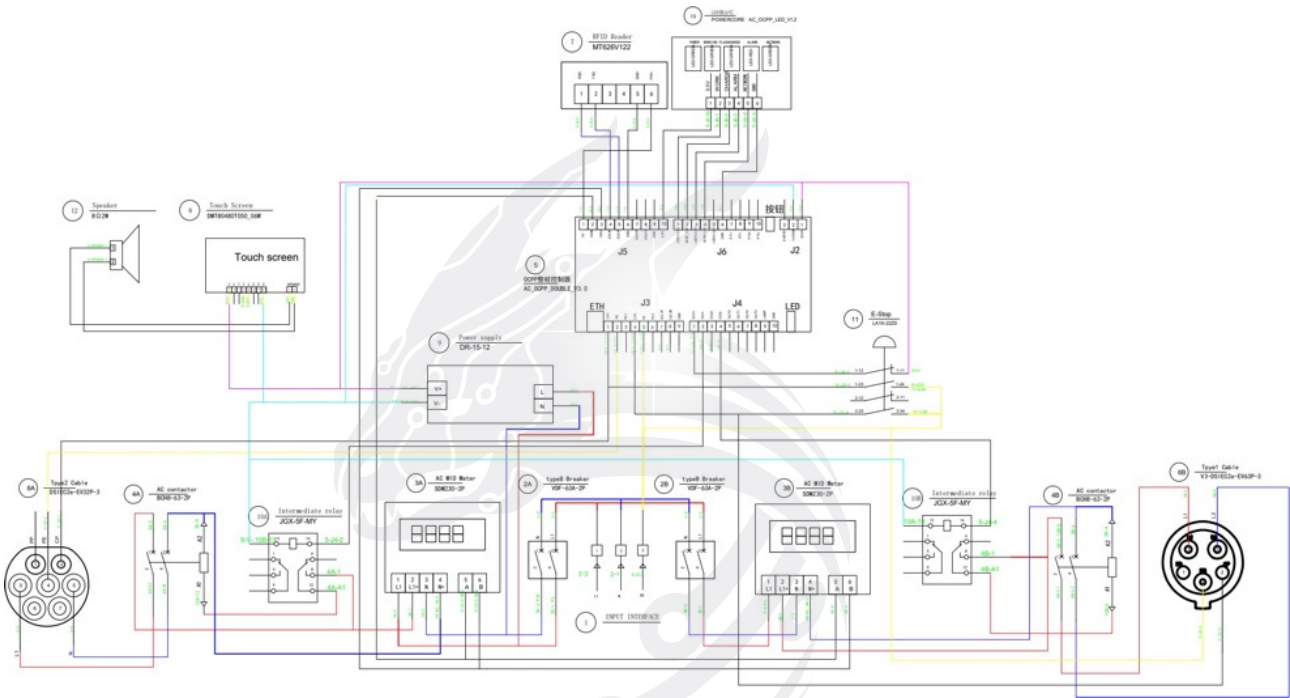

\*6A(EUR)/6B(US) plug shape is different, the plug name and definition are consistent and the wiring is identical





## RESTRICTION OF HAZARDOUS SUBSTANCES

### ELEMENT IDENTIFICATION TABLES (ROHS)

PART	TOXIC AND HARMFUL SUBSTANCES OR ELEMENTS					
	Lead	Mercury	Cadmium	Hexavalent chromium	Polybrominated biphenyl	Polybrominated diphenyl ethers
	PB	HG	CD	CR6+	PBB	PBDE
Cabinet, box and copper row	x	•	•	•	•	•
Charging module	x	•	•	•	•	•
Monitoring module	x	x	•	•	•	•
Distribution parts	x	•	x	•	•	•
Circuit board	x	•	•	•	•	•
Hardware	x	•	•	•	•	•
Cable	x	•	•	•	•	•
<p>• Indicates that this toxic or hazardous substance contained in all of the homogeneous materials for this part is below the limit requirement in SJ/T 11363-2006</p> <p>x Indicates that this toxic or hazardous substance contained in at least one of the homogeneous materials used for this part is above the limit requirement in SJ/T 11363-2006</p> <p>The following components or applications containing toxic and harmful substances are limited by the current level of technology, with no reliable alternative or solution:</p> <ol style="list-style-type: none"> <li>1. Solder contains lead</li> <li>2. Copper alloys contain lead</li> <li>3. The contacts of the switch contain cadmium</li> <li>4. The backlight tube contains mercury</li> </ol> <p>Description of the environmentally friendly use period: the environmentally friendly use period of this product (marked in the product body) refers to the period of time from the date of production of the product containing toxic and harmful substances or elements that will not have a serious impact on the environment, persons and property, subject to normal conditions of use and compliance with the safety precautions of this product.</p>						
<p>SCOPE OF APPLICATION: AC DUAL OUTLET CHARGER</p>						



## AUTHENTICATION

### CERTIFICATION

**CERTIFICATE**  
of Conformity

  
TÜVRheinland

Registration No.: AK 50443340 0001

Report No.: 50278629 001

**Holder:** Nanjing PowerCore technology co., LTD  
Room 104-9, block B,  
DongManDaSha, No.11 xinghuo road,  
Jiangbei new district, Nanjing  
P. R. China

**Product:** Controller  
Supply Equipment Communication Controller

**Identification:** Type Designation : PC-SCC12-121  
Serial No. : Engineering Sample  
Remarks:  
Refer to test report 50278629 001 for details.

**Tested acc. to:** DIN SPEC 70121/12.14

The certificate of conformity refers to the above mentioned product. This is to certify that the specimen is in conformity with the assessment requirement mentioned above. This certificate does not imply assessment of the production of the product and does not permit the use of a TÜV Rheinland mark of conformity.

Date: 08.08.2019

  
Leham Zhang  
Certification Body

TÜV Rheinland LGA Products GmbH - Tillystraße 2 - 90431 Nürnberg



## AUTHENTICATION

### CERTIFICATION



**POTVRDA O SUKLADNOSTI**  
**ATTESTATION OF CONFORMITY**

**Broj certifikata / Certificate Number :** M.2020.103.UY1196

**Proizvođač Applicant / Manufacturer :** Nanjing Powercore Tech Co., Ltd.

**Adresa proizvođača / Applicant address / Manufacturer address :** Room 104-9, Block B, Animation Building, 11 Xinghuo Road, Jiangbei New District, Nanjing, Jiangsu, China

**Opis proizvoda / Product description :** AC Charger Station

**Tip / Model / Type / Model :** NKR-AC001 (7/11/14/22/43kw), NKR-AC002(7/11/14/22/43kw), NKRAC003(7/11/14/22/43kw), NKR-AC004(7/11/14/22/43kw), NKRAC005(7/11/14/22/43kw)

**Vezana Direktiva / Related Directives :** DIREKTIVA 2014/35/EU, DIREKTIVA 2014/30/EU, LVD 2014/35/EU, EMC 2014/30/EU

**Vezani Standardi / Related Standards :** EN 61851-1:2011, EN 61851-22:2002, EN 61000-6-1:2007, EN 61000-6-3:2007+A1:2011

**Izveštaje o ispitivanju / Test report :** GOM191230196T/31.12.2019, B-S200127676/13.01.2020

UDEM Adriatic d.o.o. pregledom tehničke dokumentacije koju je dostavila tvrtka čiji su naziv i adresa gore navedeni, potvrđuje sukladnost proizvoda s Direktivama 2014/35/EU i EMC 2014/30/EU.

**CE**

Tvrtka može postaviti oznaku na proizvod, zajedno s EU izjavom o sukladnosti za čiju je izradu odgovoran proizvođač. U slučaju promjene dizajna ovog certifikata koji se odnosi na ispitani proizvod, certifikat prestaje važiti. Molim Vas provjerite valjanost certifikata na Internet stranici [www.udemadriatic.com](http://www.udemadriatic.com). Ovaj certifikat je važeći samo za gore navedeni tip/model proizvoda. UDEM i gore navedena tvrtka moraju čuvati primjerak ovog certifikata 15 godina od dana izdavanja certifikata. Ovaj certifikat je vlasništvo UDEM Adriatic d.o.o i mora biti vraćen na zahtjev. UDEM Adriatic d.o.o. confirms by examining technical documents presented on the part of company which stated title and address below that product is conformable to LVD 2014/35/EU and EMC 2014/30/EU. Company can attach CE marking on the product with EU Declaration of Conformity prepared by manufacturer in the charge of company. In case of changing the certificate design regarding to product examined, certificate will be expired. Please check validity of this certificate by website [www.udemadriatic.com](http://www.udemadriatic.com). This certificate is valid just for the product type/models stated below. UDEM and Company above mentioned must retain a copy of these certificates for 15 years since the day of registration. This certificate property belongs to UDEM Adriatic d.o.o and if required it must be returned.

**Datum izdavanja / Issue Date :** 14.01.2020  
**Vrijedi do / Validity date :** 13.01.2025





Adresa: Gajeva 2b, 1st floor Zagreb / Croatia  
Tel: +385 (1) 4819 601; Faks: +385 (1) 4819 434  
E-pošta: [info@udemadriatic.com](mailto:info@udemadriatic.com); Web: [www.udemadriatic.com](http://www.udemadriatic.com)

UDPM83-2/00-00/13.12.2018



# HYDRA<sup>®</sup>



**HYDRA<sup>®</sup>**  
**ELECTRIC VEHICLE CHARGERS**

**HYDRA EVC Ltd**

Telephone: 01268 205 121

Email: [sales@hydraev.co.uk](mailto:sales@hydraev.co.uk)

Unit 11, Totman Close, Rayleigh, Essex SS6 7UZ

GENESIS-V0003-03.01.2023